

Risky Business

INTEGRATED
CURRICULUM UNIT
ON HEALTH INSURANCE

ConnectEd: The California Center for College and Career

2150 Shattuck Avenue, Suite 1200

Berkeley, CA 94704

510-849-4945

FAX: 510-841-1076

www.ConnectEdCalifornia.org

National Consortium on Health Science and Technology Education

2410 Woodlake Drive

Okemos, MI 48864-3997

www.nchste.org

Copyright © 2007 by ConnectEd: The California Center for College and Career. All rights reserved.

Pages from this unit may be reprinted or photocopied for free distribution, with attribution to

ConnectEd: The California Center for College and Career and the National Consortium on Health Science and Technology Education.

Contributing Teacher Team:

Arthur A. Benjamin Health Professions High School

Sacramento, CA

Contributing ConnectEd Staff:

Director for Program and Curriculum Development: Paula Hudis

Curriculum Developers: Pier Sun Ho (Lead), Khanh Bui, Aaron Malloy, Charles Stephen

Publishing/Editorial Staff: Barbara Kridl, Andrea Livingston, Natesh Daniel, Patti Gildersleeve,

Alicia Broadway, Leslie Tilley, Dave Abston, Goura Fotadar McCarty, Becky Chapman-Winter

Administrative Staff: Melody Rose

Contributing NCHSTE Representatives:

Health Science and Biomedical Program of Study Project Director: Beverly Campbell

Executive Director: Carole Stacy

Coordination, Site Sponsorship, and Teacher Team Support: Nancy Allen, SeAnne Safaii, Cindy Beck,

Fran Beauman, Rhonda Patterson, Karen Batchelor, Thalea Longhurst, Jen Staley, Michael Mitchell,

Clarice Morris, Scott Snelson, Bruce Bird, Paul Jackson

Acknowledgments

ConnectEd: The California Center for College and Career and The National Consortium on Health Science and Technology Education (NCHSTE) want to thank the many people who supported this work and helped develop these integrated curriculum units. We would especially like to thank the academic and health science teachers from 12 high schools who participated in our curriculum design workshops and created and tested many of the original lessons in their classrooms. We also want to thank the principals of these schools for encouraging curriculum integration and supporting their teachers' work. Enthusiastic and creative teachers and supportive administrators have been essential to the success of the project.

The following high schools participated at various stages of the project:

California

Arthur A. Benjamin Health Professions High School (Sacramento)
Palmdale High School, Health Careers Academy (Palmdale)

Idaho

Meridian Medical Arts Charter High School (Boise)

Illinois

Westinghouse Career Academy (Chicago)
Dunbar Career Academy (Chicago)
New Millennium School of Health (Chicago)

Indiana

Owen Valley High School (Spencer)

Minnesota

John Marshall High School (Rochester)

New York

Gorton High School Academy of Medical Professions (Yonkers)

South Carolina

Beaufort High School (Beaufort)

Texas

Ben Barber Career and Technology Academy (Mansfield)

Utah

Northridge High School (Layton)

We also want to thank many contributing representatives from NCHSTE and local school districts who helped coordinate beta testing activities, sponsored school sites, and provided support to the teachers. These individuals include Nancy Allen, Karen Batchelor, Fran Beauman, Cindy Beck, Bruce Bird, Jan Cabbell, Paul Jackson, Thalea Longhurst, Rhonda Patterson, Michael Mitchell, Clarice Morris, SeAnne Safai, Scott Snelson, and Jen Staley. Carole Stacy, NCHSTE's Executive Director, played many essential roles at every stage of this work.

Thanks, also, to Intermountain Healthcare, Salt Lake City, Utah and the Mayo Clinic, Rochester, Minnesota. Both of these organizations generously provided facilities and opportunities for guided study tours that were an important component of our teacher professional development workshops.

A talented group of curriculum designers at ConnectEd worked with the original lessons created by the teacher teams and expanded their material to create full curriculum units. The team was led by Pier Sun Ho, and also included Khanh Bui, Aaron Malloy, and Charles Stephen.

We gratefully acknowledge the publishing, editorial, and design work provided by MPR Associates, Inc. staff, including Barbara Kridl, Andrea Livingston, Natesh Daniel, Patti Gildersleeve, and Alicia Broadway. They were assisted by Leslie Tilley, Dave Abston, Goura Fotadar McCarty, and Becky Chapman-Winter. Melody Rose ably provided project administrative support.

Major funding for this work came from the James Irvine Foundation and from MPR Associates, Inc. The State Directors of Career Technical Education in California, Idaho, Illinois, Indiana, Minnesota, South Carolina, Texas, and Utah, along with the Director of Career Development and Occupational Studies, Yonkers (New York) Public Schools provided funding for teacher professional development and classroom-based curriculum design and testing. We were fortunate to receive seed money at the start of the project from The Office of Vocational and Adult Education at the U.S. Department of Education.

Acknowledgments

Finally, we want to thank two individuals who provided tremendous support for this effort. Anne Stanton, Director of the Youth Program at the James Irvine Foundation and Gary Hoachlander, President of ConnectEd and MPR Associates, Inc. have promoted a new way of thinking about how to engage students in learning with the goals of improving academic outcomes and closing the achievement gap. They have encouraged us to create interdisciplinary curriculum material that delivers challenging, college- and career-preparatory academic and technical learning through authentic, career-focused applications. We hope that using this curriculum enlivens your classroom, excites your students to learn, and helps them achieve academic and career success.

Paula M. Hudis
Director for Program and Curriculum Development
and Project Director for
ConnectEd

Beverly Campbell
Principal, BECGroup Consulting and
Health Science and Biomedical Program of Study
Project Director, NCHSTE

September 2007

Risky Business

CONTENTS

	Page
Unit Overview	1
Subunit 1 Overview	
Lesson 1.1 Health Science	
Lesson 1.2 U.S. History	
Lesson 1.3 Health Science	
Lesson 1.4 English Language Arts	
Subunit 2 Overview	
Lesson 2.1 Biology	
Lesson 2.2 Biology	
Lesson 2.3 Biology	
Lesson 2.4 Health Science	
Lesson 2.5 English Language Arts	
Lesson 2.6 Spanish I	
Subunit 3 Overview	
Lesson 3.1 Health Science	
Lesson 3.2 Algebra I	
Lesson 3.3 Algebra I	
Lesson 3.4 Physical Education	
Lesson 3.5 English Language Arts	
A Risky Business	3
<i>Insurance Is a Risky Business</i>	5
<i>An Unhealthy History</i>	19
<i>Alphabet Soup</i>	27
<i>Starting an Insurance Company Part 1: The Vision</i>	29
Knowing the Risks	33
<i>Investigating Inherited Traits</i>	35
<i>Predicting With Punnett Squares</i>	41
<i>Pedigree Charts</i>	53
<i>High-Risk Behaviors</i>	61
<i>High-Risk Behaviors Workplace Brochure</i>	65
<i>Impact of Environment and Society on Health and Wellness</i>	69
Making Decisions	73
<i>Starting an Insurance Company Part 2: The Policies</i>	75
<i>Dice With Death: Probability in Mortality Tables</i>	87
<i>Medical Coverage Choices</i>	91
<i>Designing a Wellness Program</i>	95
<i>Starting an Insurance Company Part 3: Choosing Clients</i>	99

Risky Business

UNIT OVERVIEW

Essential Question for This Unit

How can we balance personal freedoms and society's need to provide accessible, affordable healthcare?

Unit Summary

Students will learn about lifestyle and genetic influences on health status and about the health insurance system in the United States. They will imagine a future healthcare environment in which technology has greatly advanced, treatment costs have escalated, and individual lifestyle and medical data are widely available to insurers. In this scenario, insurance companies routinely use this kind of information to create programs aimed at improving health outcomes, set insurance rates, approve or deny applications for health insurance, and reduce healthcare expenses.

In Subunit 1, students learn about the importance of having health insurance. They are introduced to the various types of medical insurance plans, learn how insurance covers the costs of medical treatment, and study how the industry has evolved in the United States. Working in small groups, students form their own insurance companies.

In Subunit 2, students research the influence of high-risk behaviors and inherited factors on health outcomes, focusing heavily on the heritability of various diseases and the effects of modifying high-risk behaviors on health outcomes.

In Subunit 3, acting as officers of their insurance companies, students evaluate hypothetical profiles of insurance applicants that include medical histories and data concerning high-risk behaviors. They use this information to decide whether to approve applicants for health insurance coverage and to determine the premiums they will be charged. Students also propose steps that their insurance companies and applicants can take to reduce rates of illness and injury and mortality from high-risk behaviors and inherited influences on health status.

Culminating Event

Student participation in the unit could culminate with a schoolwide health fair. As representatives of their fictitious insurance companies, groups of students will create and display a presentation detailing their decisions to approve or deny medical insurance and to set insurance rates. Presentations will include research findings about relevant medical conditions and lifestyle factors and a risk analysis for hypothetical insurance applicants. They will also include letters sent by the insurance company to each applicant—detailing the company's decision—and marketing materials designed to promote the company's efforts to improve the health outcomes of policyholders and members of health systems.

Key Questions/Issues

- Why is healthcare so expensive, and where does the money go? Why do some people travel to Canada or Mexico to buy prescription drugs? What are the risks and benefits associated with buying medication abroad? (U.S. History, Health Science, and Spanish I)
- What determines insurance rates? What makes insurance cost more for some individuals than for others? (Algebra I)
- How can individuals reduce their insurance and healthcare costs? (Health Science and English Language Arts)
- Who should be responsible for paying for healthcare: individuals, businesses, and/or the government? What role might each play in promoting national health? (U.S. History)
- What rights do employers have to limit employees' personal activities? (U.S. History and Physical Education)
- How do genetics account for individual differences in various characteristics? That is, why do I look like/different from my parents and siblings, and why do I have similar/different health-related characteristics? (Biology)

- Are you destined to follow in your parents’ footsteps in terms of health? What factors are beyond individual control, and what factors can be manipulated? (Biology and Health Science)
- What accounts for differences in life expectancy and infant mortality in various parts of the world? (Spanish I)
- What can social, government, and philanthropic programs do—and what are they doing—to improve public health? (U.S. History and Spanish I)

Learning Scenario to Kick Off the Unit

The Ski Club’s annual trip to Lake Tahoe is just around the corner. In a triumph of planning and lucky timing, the club has managed to schedule the trip on the very same weekend that Squaw Valley is offering a packaged workshop on extreme aerials by a member of the U.S. Olympic Ski Team. The members of the club are ecstatic. Enthusiasm had reached a fever pitch when, 2 days before the trip, the principal announced that participating in the aerials workshop was forbidden. Despite student protests, the principal explained that the district office had informed him that the school’s field trip liability insurance could not cover such a high-risk activity. If anything happened, the district’s insurance premiums would rise. He said that the district’s budget is already stretched to the limit and they cannot afford additional insur-

ance. It might be possible to pass the insurance costs on to individual students, but the trip is already very expensive and not everyone can afford to pay more. The club has been fund raising for weeks to cover all the costs, and coming up with more money at this late date seems unrealistic. The club president thinks the district is exaggerating the risk. A district official has agreed to meet with representatives of the club to discuss the situation. What should be done? What arguments can the club present that will convince a skittish district? Why has the district adopted their position?

Biomedical/Healthcare and Education Partner Roles

- Representatives from local healthcare institutions and insurance companies will play key roles providing a real-world context.
- Speakers from various professions will participate. These include:
 - Actuaries
 - Benefits Managers
 - Health Information Technicians
 - Insurance Processors
- Professionals from local healthcare partners will play key assessment roles, serving as evaluators for the culminating event.

SUBUNITS AND MAJOR TOPICS (ACROSS ACADEMIC AND TECHNICAL SUBJECT AREAS)

Subunit 1 <i>A Risky Business</i>	Subunit 2 <i>Knowing the Risks</i>	Subunit 3 <i>Making Decisions</i>
HEALTH SCIENCE · U.S. HISTORY · ENGLISH LANGUAGE ARTS	BIOLOGY · ENGLISH LANGUAGE ARTS · SPANISH I · HEALTH SCIENCE	ALGEBRA I · ENGLISH LANGUAGE ARTS · HEALTH SCIENCE · PHYSICAL EDUCATION
<ul style="list-style-type: none"> • Health insurance options in the United States • Evolution of the health insurance industry • U.S. healthcare legislation and its impact on the healthcare and insurance systems • Determination of rates and fees in the healthcare system • Analysis of medical insurance payment options • Print and multimedia design 	<ul style="list-style-type: none"> • Inheritance and expression of physical traits, including such topics as dominant and recessive alleles, phenotype vs. genotype, genetic ratios and Punnett squares, autosomal vs. X-linked genetic disorders, and pedigree charting • Structural features of writing informational materials • Multimedia research and presentation skills • Healthcare systems and health status in Latin America, including comparisons and analyses of health status for various population groups in the United States 	<ul style="list-style-type: none"> • Human wellness and preventative measures • Qualitative cost vs. benefit lifestyle analysis • Quantitative insurance risk assessment analysis • Linear equations • Probability theory

A Risky Business

SUBUNIT 1 OVERVIEW

Essential Question for This Unit

How can we balance personal freedoms and society's need to provide accessible, affordable healthcare?

Subunit Goals

In Subunit 1, students are introduced to health insurance. Students will describe the purpose and function of health insurance, understand the burden of living without insurance, outline the history of the health insurance industry, and interpret expenses associated with its cost. Students will also analyze, evaluate, and compare medical insurance plans and providers. Using that information, students will create a name, design a logo, and compose a slogan and mission for their own fictional insurance company. They will tie the mission to key health improvement goals.

Subunit Key Questions

- What is health insurance? How does it compare to other types of insurance? Is it important to have health insurance? (Health Science)
- Why is healthcare so expensive, and where does the money go? (Health Science)
- Who should be responsible for paying for healthcare: individuals, businesses, and/or the government? What role might each play in promoting national health? (Health Science and U.S. History)
- How does health insurance in the United States compare with that in other countries? What has influenced how health insurance is provided in the United States? (U.S. History)
- How has the insurance industry changed over the years? (U.S. History)
- How can companies use print and multimedia resources to communicate their missions and policies effectively and attract consumers? (English Language Arts)

Lesson Summaries

Lesson	Subject	Description
1.1	Health Science	<i>Insurance Is a Risky Business</i> Students are introduced to important insurance ideas and terms, and assess the importance of health insurance through a simple simulation.
1.2	U.S. History	<i>An Unhealthy History</i> Students outline the history of medical insurance in the United States and debate its merits in different historical contexts.
1.3	Health Science	<i>Alphabet Soup</i> Students research and compare different contemporary insurance companies and plans.
1.4	English Language Arts	<i>Starting an Insurance Company Part I: The Vision</i> Students create their own insurance company, its logo, slogan, and mission.

Subunit 1—A Risky Business

Insurance Is a Risky Business

LESSON 1.1

HEALTH SCIENCE

Time

90 minutes

Materials

Resources

- Lecture Notes:
 - Medical Insurance
- Insurance Consumer Cards
- Health Event Cards

Prior Student Learning

Students should have a general knowledge of the concept of insurance and why it is useful.

Students should have a basic understanding of where money in the healthcare industry is spent (e.g., healthcare personnel services, technology, and facility operations and maintenance, etc.).

Essential Question for This Unit

How can we balance personal freedoms and society's need to provide accessible, affordable healthcare?

Objectives

After completing this lesson, students should be able to

- Describe the purpose and function of medical insurance.
- Analyze the components of healthcare services.
- Explain expenses associated with healthcare costs.
- Differentiate among several payment options.
- Analyze the benefits and drawbacks of having medical insurance.

Lesson Activities

Lesson Springboard

Introduce the following scenario:

A friend of yours breaks his arm playing basketball. He is rushed to the hospital where they set his arm and put on a cast. He goes home later in the day. Weeks later he receives the bill. It is a staggering \$1,200. You talk to him on the phone and find out that he was uninsured and that his family is trying to figure out how to pay. They just don't have the money. After hanging up, you realize that the same thing could happen to you. You go online and find out that with insurance, the cost would have only been \$300. But you would have to pay a \$100 monthly premium to have the insurance. Looking at your own future, what do you do?

Explain to students that in this unit, they will examine health insurance and create their own health insurance company. Ask them what they know about health insurance. This provides an opportunity to assess their prior knowledge and any misconceptions they may have.

After a short discussion, let students know that you will return to the scenario and discussion after they learn more about how insurance works.

Lesson Development

Direct Instruction

Introduce the concept of health insurance and how much Americans spend on it. Where does the money come from? Individuals, employers, and government entities? Explain that, as your friend discovered and you learned from your preliminary research, healthcare is expensive. Highlight the reasons for the high cost of health insurance and emphasize the fact that students will be spending more time in the upcoming

Insurance Is a Risky Business

LESSON 1.1

weeks discussing how social issues, such as an aging population, access to care, and risky behaviors, influence healthcare costs.

Return to the scenario and explain that there are several insurance options open to the students and their friends. Introduce the major methods of payment: fee for service and insurance plans (e.g., managed care, HMO, PPO, and government programs). Finally, introduce some related terms (e.g., premium, deductible, co-payment).

Class Discussion

Now that students have a better idea of the different payment options, they should use their notes and new information to discuss the following:

- What would be the best option to avoid your friend's dilemma?
- What other information would you need to decide what kind of health insurance to purchase?
- Do you think that the costs of insurance are justified?

Insurance Simulation Game

Have students play the following game to see the financial benefits and costs of having health insurance. Playing the game will also generate additional questions that will be useful in learning about the function of healthcare companies. Make 12 Health Event Card decks by photocopying and cutting out the cards on the associated student worksheets. Each deck should contain one photocopy of every Health Event, and 5 "No Illness or Injury" cards. Also, make a deck of Insurance Consumer Cards, half "insured" and half "uninsured."

Explain the game play as follows:

1. Students assemble into groups of four to six.
2. Each student is randomly assigned an Insurance Consumer Card (insured or uninsured).
3. Students take turns picking cards from the Health Events Card deck. Each time a student picks a card, it represents 1 month.
4. After picking up a card, the student reads it aloud and records how much money he or she needs to spend.
5. Students who are paying for insurance must remember to include their monthly premium as a cost every month even if there is no illness.
6. Students record and compare how much money they have spent every 6 months.
7. At the end of the time allotted, students discuss the individual differences in the amount of money they have spent on healthcare.

Lesson Closure

Discuss with the class their conclusions regarding insurance. Was insurance worth the initial cost? Who spent more money, the insured or uninsured? Going back to the initial scenario, should you sign up for

Insurance Is a Risky Business

LESSON 1.1

insurance? What has this game communicated about the relative importance of insurance? Be sure to include some discussion on whether or not the game was a realistic simulation. Tell students they will review the game again after learning more about insurance to see if there are design improvements that could be made.

Possible Prior Misconceptions

Some students may believe that everyone who has insurance pays no money when they go to the hospital.

Some students may believe that the money people pay for insurance goes directly into the pockets of the insurance companies, or all of the money is passed on to healthcare providers.

Some students may believe that there is only one type of insurance, and people are either insured or uninsured.

Student Assessment Artifacts

Lecture notes on medical insurance
Healthcare expenditure calculations

Variations and Extensions

Expand and/or revise the Health Events Card deck to better reflect specific consumer types (single vs. married, young vs. old, kids vs. no kids, and so on), and run multiple versions of the game to see if students get different results or draw different conclusions.

National and State Career and Technical Education Standards

NATIONAL

NCHSTE National Healthcare Skill Standards

Foundation Standard 3: Systems

Healthcare workers will understand how their role fits into their department, their organization and the overall healthcare environment. They will identify how key systems affect services they perform and quality of care.

3.2 Healthcare Delivery System

- 3.21 Construct a healthcare delivery system model
- 3.22 Predict where and how factors such as; cost, managed care, technology, an aging population, access to care, alternative therapies, and lifestyle/behavior changes may affect various healthcare delivery system models

CALIFORNIA

Health Sciences and Medical Technology Standards

10.0 Technical Knowledge and Skills

- 10.1 Understand the process for determining mission statements, goals, objectives, and strategic plans for a healthcare organization and understand the process for using appropriate policies, procedures, and processes as defined by the scope of practice of a specific healthcare organization.
- 10.2 Understand how the healthcare delivery systems models can be affected by cost, managed care, technology, an aging population, access to care, alternative therapies, and lifestyle and behavior changes.

Name _____ Date _____ Period _____

Lecture Notes: Medical Insurance

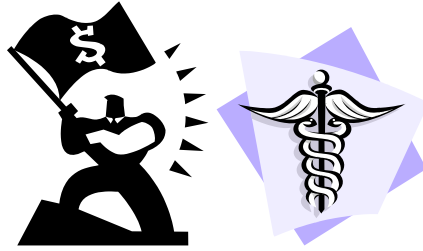

I. Healthcare Costs

- Healthcare is a _____ in the United States that makes up _____ of our economy.
- In 2004 _____ spent on healthcare costs (_____ per person).

II. Why Is Healthcare so Expensive?

- _____
- _____
- _____
- _____
- _____
- _____

Example: _____

III. Where Does the Money Go?

- _____
- _____
- _____

IV. Methods of Payment

- Fee for service = _____
- Insurance Plans
 - Definition: An agreement in which a person being insured pays a regular fee to an insurance company, and, in return, the company pays for certain healthcare expenses ... such as _____

Name _____ Date _____ Period _____

V. Where Do You Get Insurance?

- _____
- _____
- _____

VI. Types of Insurance

1. _____
 - o Examples: Blue Cross, Blue Shield
 - o Patient visits _____ health provider
 - o Insurance pays a certain amount of fee (like _____%)

2. _____
 - o Focuses on _____
 - o The Plan or Agency _____ your care
 - o HMO = _____
 - A group of Physicians and HCW provide complete coverage for members
 - Must use _____
 - Need permission for _____
 - Small _____
 - Physicians are on _____
 - o PPO = _____
 - Similar to HMO, but more _____
 - You can see specialists outside the plan, but you _____

3. _____
 - o Medicare
 - Federal Government Program
 - Provides healthcare for people over _____ and for some people with _____
 - _____ coverage
 - o _____ (MediCal in California)
 - _____
 - Pays for some coverage for _____ or low-income people (includes children and _____)

Name _____ Date _____ Period _____

INSURANCE TERMS

1. _____ are fees based on Diagnostic-Related Groupings: _____
to keep costs reasonable

2. _____ = a fee paid (usually monthly) to the insurance company
in _____

Example: _____

3. _____ = amounts paid by patient to the medical provider

4. Co-payment:

Name _____ Date _____ Period _____

Lecture Notes: Medical Insurance

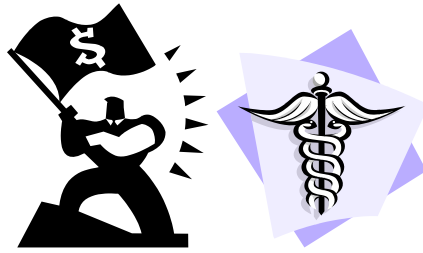

I. Healthcare Costs

- Healthcare is a Business in the United States that makes up 15% of our economy.
- In 2004 \$1.9 trillion spent on healthcare costs (\$6000 per person).

II. Why Is Healthcare so Expensive?

- Cost of Medical Technology
- Insurance Administration
- Lawsuits and Malpractice
- Aging Population
- Pharmaceutical (Drug) Costs
- Social Problems

Example: violence, drug abuse, teen pregnancy, childhood obesity

III. Where Does the Money Go?

- Services (salaries, etc.)
- Products & Supplies
- Research & Education

IV. Methods of Payment

- Fee for service = Money is paid at time of service.
- Insurance Plans
 - Definition: An agreement in which a person being insured pays a regular fee to an insurance company, and, in return, the company pays for certain healthcare expenses ... such as annual preventative care and catastrophic events.

Name _____ Date _____ Period _____

V. Where Do You Get Insurance?

- Groups (work/employer) _____
- Individuals _____
- Government benefits (ex: military) _____

VI. Types of Insurance1. Traditional _____

- o Examples: Blue Cross, Blue Shield
- o Patient visits any health provider
- o Insurance pays a certain amount of fee (like 80 %)

2. Managed Care _____

- o Focuses on prevention _____
- o The Plan or Agency manages your care
- o HMO = Health Maintenance Organization _____
 - A group of Physicians and HCW provide complete coverage for members
 - Must use HMO doctors and facilities _____
 - Need permission for specialists _____
 - Small co-payments _____
 - Physicians are on salary _____
- o PPO = Preferred Provider Organization _____
 - Similar to HMO, but more freedom _____
 - You can see specialists outside the plan, but you pay more _____

3. Government Plans _____

- o Medicare
 - Federal Government Program
 - Provides healthcare for people over 65 and for some people with disabilities _____
 - Limited coverage
- o MEDICAID _____ (MediCal in California)
 - State run program _____
 - Pays for some coverage for poor or low-income people (includes children and teens)

Name _____ Date _____ Period _____

INSURANCE TERMS

1. DRGs are fees based on Diagnostic-Related Groupings: federal guidelines to keep costs reasonable
2. Premium = a fee paid (usually monthly) to the insurance company in return for coverage
Example: \$500 a month
3. Deductible = amounts paid by patient to the medical provider
before the insurance co. will begin to pay
4. Co-payment:
A specific amount of money paid for a service or medication (example: \$15.00 per hospital visit)

Name _____ Date _____ Period _____

Insurance Consumer Cards

<p>Insured</p> <p>Pay \$250/month</p>	<p>Uninsured</p> <p>Pay \$0/month</p>
--	--

Health Event Cards

<p>Broken leg</p> <p>Cost with insurance: \$500 Cost without insurance: \$5,200</p>	<p>Allergic reaction to bee sting</p> <p>Cost with insurance: \$250 Cost without insurance: \$1,000</p>
<p>5 stitches in the lip (basketball accident)</p> <p>Cost with insurance: \$150 Cost without insurance: \$700</p>	<p>Broken wrist</p> <p>Cost with insurance: \$300 Cost without insurance: \$2,800</p>
<p>Broken ankle</p> <p>Cost with insurance: \$300 Cost without insurance: \$2,800</p>	<p>Blood pressure pills</p> <p>Cost with insurance: \$200 Cost without insurance: \$800</p>
<p>Broken finger</p> <p>Cost with insurance: \$300 Cost without insurance: \$2,800</p>	<p>Lung cancer</p> <p>Cost with insurance: \$4,500 Cost without insurance: \$48,000</p>
<p>7 stitches across the forehead (biking accident)</p> <p>Cost with insurance: \$200 Cost without insurance: \$800</p>	<p>Appendicitis</p> <p>Cost with insurance: \$350 Cost without insurance: \$4,300</p>

Name _____ Date _____ Period _____

<p>Diagnosed with breast cancer</p> <p>Cost with insurance: \$500 Cost without insurance: \$2,000</p>	<p>Strep throat</p> <p>Cost with insurance: \$150 Cost without insurance: \$300</p>
<p>Annual physical exam</p> <p>Cost with insurance: \$50 Cost without insurance: \$150</p>	<p>Athlete's foot</p> <p>Cost with insurance: \$60 Cost without insurance: \$200</p>
<p>Annual physical exam</p> <p>Cost with insurance: \$50 Cost without insurance: \$150</p>	<p>Wart removal</p> <p>Cost with insurance: \$100 Cost without insurance: \$400</p>
<p>Allergic reaction to shellfish</p> <p>Cost with insurance: \$250 Cost without insurance: \$1,000</p>	<p>Genital herpes</p> <p>Cost with insurance: \$200 Cost without insurance: \$800</p>
<p>Diagnosed with cervical/testicular cancer</p> <p>Cost with insurance: \$500 Cost without insurance: \$2,000</p>	<p>Chlamydia</p> <p>Cost with insurance: \$150 Cost without insurance: \$600</p>
<p>Pre-cancerous mole removal</p> <p>Cost with insurance: \$150 Cost without insurance: \$600</p>	<p>Migraine medications</p> <p>Cost with insurance: \$200 Cost without insurance: \$800</p>
<p>Asthma</p> <p>Cost with insurance: \$250 Cost without insurance: \$1,000</p>	<p>Pneumonia</p> <p>Cost with insurance: \$500 Cost without insurance: \$4,000</p>

Name _____ Date _____ Period _____

<p style="text-align: center;">Broken arm</p> <p style="text-align: center;">Cost with insurance: \$300 Cost without insurance: \$1,200</p>	<p style="text-align: center;">Pregnancy</p> <p style="text-align: center;">Cost with insurance: \$1,000 Cost without insurance: \$6,000</p>
<p style="text-align: center;">Stomach ulcer</p> <p style="text-align: center;">Cost with insurance: \$2,500 Cost without insurance: \$10,000</p>	<p style="text-align: center;">Urinary tract infection</p> <p style="text-align: center;">Cost with insurance: \$150 Cost without insurance: \$600</p>
<p style="text-align: center;">Depression</p> <p style="text-align: center;">Cost with insurance: \$250 Cost without insurance: \$1,000</p>	<p style="text-align: center;">Food poisoning</p> <p style="text-align: center;">Cost with insurance: \$150 Cost without insurance: \$600</p>
<p style="text-align: center;">ACL tear (knee injury)</p> <p style="text-align: center;">Cost with insurance: \$1,200 Cost without insurance: \$3,800</p>	<p style="text-align: center;">Sports injury head trauma</p> <p style="text-align: center;">Cost with insurance: \$300 Cost without insurance: \$1,200</p>
<p style="text-align: center;">Heart attack</p> <p style="text-align: center;">Cost with insurance: \$4,000 Cost without insurance: \$16,000</p>	<p style="text-align: center;">Severe allergies</p> <p style="text-align: center;">Cost with insurance: \$200 Cost without insurance: \$800</p>
<p style="text-align: center;">Hernia surgery</p> <p style="text-align: center;">Cost with insurance: \$500 Cost without insurance: \$5,000</p>	<p style="text-align: center;">Meningitis</p> <p style="text-align: center;">Cost with insurance: \$250 Cost without insurance: \$1,000</p>
<p style="text-align: center;">Diabetes</p> <p style="text-align: center;">Cost with insurance: \$1,000 Cost without insurance: \$9,000</p>	<p style="text-align: center;">Post Traumatic Stress Disorder</p> <p style="text-align: center;">Cost with insurance: \$250 Cost without insurance: \$1,000</p>

Name _____ Date _____ Period _____

☺ No injuries or illnesses ☺	☺ No injuries or illnesses ☺
☺ No injuries or illnesses ☺	☺ No injuries or illnesses ☺
☺ No injuries or illnesses ☺	☺ No injuries or illnesses ☺
☺ No injuries or illnesses ☺	☺ No injuries or illnesses ☺
☺ No injuries or illnesses ☺	☺ No injuries or illnesses ☺
☺ No injuries or illnesses ☺	☺ No injuries or illnesses ☺
☺ No injuries or illnesses ☺	☺ No injuries or illnesses ☺
☺ No injuries or illnesses ☺	☺ No injuries or illnesses ☺

An Unhealthy History

LESSON 1.2

U.S. HISTORY

Time

90 minutes

Materials

Equipment

Envelopes with important event slips of paper

Resources

Healthcare Timeline

How Medicaid Works

Medicaid At-a-Glance

Prior Student Learning

Students should have an understanding of healthcare and its basic functions.

Students should have a general understanding of U.S. history's major political movements.

Essential Question for This Unit

How can we balance personal freedoms and society's need to provide accessible, affordable healthcare?

Objectives

After completing this lesson, students should be able to

- Identify and order important events and movements in the history of American healthcare.
- Differentiate political philosophies associated with positions on the issue of socialized healthcare.
- Judge arguments for and against healthcare from different historical perspectives.
- Determine whether or not a given individual is eligible for public health insurance services.

Lesson Activities

Lesson Springboard

Explain to students that although healthcare is a hotly debated issue in today's government and media, this was not always the case. As late as the turn of the 20th century, healthcare insurance was a small industry. In this lesson, students will learn about how insurance has become what it is today.

Lesson Development

Small Group Work

Divide students into small groups (three to five students). Hand out one envelope with slips of paper showing important events (without dates) in the history of medical insurance and of the United States. A sample Healthcare Timeline is provided, but you may want to emphasize or include different events (e.g., passage of health insurance legislation in Europe, shift from the use of homecare to hospitalization, and the Progressive Movement).

Have students work in groups to arrange the events in a timeline, based only on the information on the slips. Students are not expected to be able to identify the chronology of events correctly. This activity will help illustrate student misconceptions about the availability of healthcare.

Subunit 1—A Risky Business
An Unhealthy History

LESSON 1.2

Direct Instruction

If resources permit, hand out enough envelopes with events so that every student can have one. Introduce the important events in chronological order, fleshing out the impetuses and stories of discovery and debate. Have students rearrange their paper slips into the correct order as you present the information. Further information on the history of the U.S. health insurance industry can be found at <http://faculty.smu.edu/tmayo/health%20care%20timeline.htm> and http://www.pbs.org/newshour/indepth_coverage/health/uninsured/timeline/index.html.

After completing the chronology, have students create a correct timeline and add notes from memory.

Health Insurance Debate

Each group will engage in a short debate over the pros and cons of introducing health insurance from a different historical perspective. Those contexts might be (1) the Progressive Era, (2) post-World War I, (3) the Depression, (4) post-World War II, and (5) today. In each debate, members might include a European doctor, an American doctor, a pharmacist or pharmaceutical company, American liberal and conservative politicians, a unionist, and any number of citizens.

Class Discussion

Review the information just presented by discussing the following questions:

- What were the major ideas and events that helped the health insurance movement?
- What were the major ideas and events that hurt the health insurance movement?
- How did the debate change over time?

Reading

Explain that public health insurance is available for certain groups of people who have no private health insurance or inadequate health insurance. There are three major public health insurance programs: Medicare, Medicaid, and the State Children's Health Insurance Program (SCHIP). In general, Medicare is a health insurance program for people over age 65 and certain people with disabilities; Medicaid provides insurance for individuals and families of low income; and SCHIP provides insurance specifically for uninsured children. Tell students that public health insurance services like Medicaid can be available to all eligible residents of the United States, in many cases, even those who are not citizens.

Place students into pairs or foursomes. Pass out the How Medicaid Works questions and copies of the Medicaid At-a-Glance pamphlet to each group. (You can check at the bottom of the U.S. Department of Health

Subunit 1—A Risky Business
An Unhealthy History

LESSON 1.2

and Human Services website for a newer version of the Medicaid guide:
<http://www.cms.hhs.gov/MedicaidGenInfo/>)

Review the answers to these questions as a class. If time permits, have students go to your state Medicaid website to research additional information on eligibility requirements and services specific to your state.

Lesson Closure

Though it has been a rather uneven history, today health insurance companies—along with government entities, consumer groups, and professional associations—are major players in shaping policies related to the healthcare industry. Have students write a short paragraph describing whether the United States health insurance system is or is not adequate to meet everyone's needs.

Possible Prior Misconceptions

Some students may believe that socialized healthcare is a communist concept.

Some students may believe that health insurance has been in existence as long as the country.

Some students may believe that the government has always provided healthcare options for the poorest citizens.

Student Assessment Artifacts

Healthcare Timeline student notes
Student debates and discussion

Variations and Extensions

Have students research the history of healthcare systems in various countries and compare their development and coverage to that in the United States.

Have students write a position paper outlining their ideas on healthcare from a historical perspective.

Have students interview family members on their viewpoints about healthcare.

An Unhealthy History

LESSON 1.2

National and State Academic Standards

NATIONAL

NCSS Curriculum Standards for Social Studies

V. Individuals, Groups, and Institutions

Social studies programs should include experiences that provide for the study of interactions among individuals, groups, and institutions, so that the learner can:

- a. apply concepts such as role, status, and social class in describing the connections and interactions of individuals, groups, and institutions in society;
- b. analyze group and institutional influences on people, events, and elements of culture in both historical and contemporary settings;
- c. describe the various forms institutions take, and explain how they develop and change over time;
- f. evaluate the role of institutions in furthering both continuity and change;
- g. analyze the extent to which groups and institutions meet individual needs and promote the common good in contemporary and historical settings.

CALIFORNIA

History–Social Science Content Standards

United States History and Geography

- 11.5 Students analyze the major political, social, economic, technological, and cultural developments of the 1920s.
- 11.6 Students analyze the different explanations for the Great Depression and how the New Deal fundamentally changed the role of the federal government.
- 11.8 Students analyze the economic boom and social transformation of post-World War II America.
- 11.11 Students analyze the major social problems and domestic policy issues in contemporary American society.

Name _____ Date _____ Period _____

Healthcare Timeline

1740–1840	Anyone can practice “medicine.” There is no required training. Most people are treated at home and doctors are paid directly by patients out of their own pockets. Hospitals serve mostly the poor and homeless. They are financed through taxes and charity, but function to isolate and maintain the ill, rather than cure them.
1840	Migration of workers to cities gives rise to the “voluntary hospital” where middle-class people go to be treated and recuperate, rather than receive care at home. Hospitals and physicians are paid by individuals.
1847	Physicians get organized and structure education and training programs for new doctors. The American Medical Association (AMA) is founded.
1870	Railroad, mining, and other large industries retain company doctors to treat employees, paid for by deductions from the workers’ salaries.
1910	Medical education and practice becomes standardized. The prestige and income for the profession increases dramatically, accompanied by a rise in healthcare costs for patients.
1911	Progressive reformers begin to call for health insurance programs.
1913	Workers Unions begin to offer medical services to their members.
1915–1920	Mandatory health insurance programs are debated and rejected by 16 states.
1930s	Depression creates cash flow problems for hospitals, prompting the creation of Blue Cross, a structured, pooled financing system for healthcare, which could be purchased by private individuals. Physicians follow by starting Blue Shield.
1943	Employers begin offering health insurance as a benefit (perk) to attract employees.
1960	Rising medical fees result in hospital care becoming prohibitively expensive for those without health insurance, and health insurance becomes increasingly expensive for those outside the workplace.
1965	Medicare and Medicaid are created to reduce the number of elderly Americans living in poverty by guaranteeing health insurance to older U.S. residents.

Name _____ Date _____ Period _____

1973	President renames prepaid group healthcare plans “Health Maintenance Organizations,” or HMOs, and provides them with federal endorsement, certification, and funding.
1985	Federal law requires employers to provide partially subsidized health insurance (COBRA) to terminated employees for 18 months after they lose their jobs.
1988	Employers move away from “fee for service” insurance systems toward HMOs and “managed care.”
1997	Congress adopts the Children’s Health Insurance Program to cover uninsured children in the United States.
2003	Significant changes are made to Medicare in the form of private prescription drug discount plans, and the introduction of competition between health plans.
2006	Massachusetts mandates statewide health insurance within 3 years.

Name _____ Date _____ Period _____



How Medicaid Works

Find the answers to the questions below using the Medicaid-At-a-Glance pamphlet.

1. What is the difference between the roles of the federal government and state government in the management of the Medicaid Program?
2. If you live in California, and then move to New Mexico, will your Medicaid eligibility be the same? Why or why not?
3. What three types of individuals qualify for Medicaid? Provide a general description of each group in your own words.
4. Where can you find out if someone qualifies for the Medicaid Program?
5. How is the State Children's Health Insurance Programs different from Medicaid?
6. Do Medicaid services usually include going to the hospital if you're physically sick?
7. Do Medicaid services usually include medical checkups for kids?
8. Do Medicaid services usually include going to the dentist?
9. Do Medicaid services usually include care during pregnancy and birth?
10. Typically, kids can receive Medicaid services if their family's income is under 100 to 133% of the Federal Poverty Level Guidelines (see page six of the pamphlet). The Federal Poverty Level Charts show the percentages of the annual and monthly income guidelines for different-sized families living in various states. For example, the 133% Federal Poverty Level yearly income threshold for a family of six living in Alaska is \$43,025.50. In your state, what is:
 - a. The 100% yearly guideline for a family of four?
 - b. The 100% monthly guideline for a family of six?
 - c. The 133% yearly guideline for a family of five?
 - d. The 133% monthly guideline for a family of seven?
11. Look at the chart on pages 7–11. What Medicaid services are provided by your state?

Name _____ Date _____ Period _____

DEPARTMENT OF HEALTH AND HUMAN SERVICES
CENTERS FOR MEDICARE & MEDICAID SERVICES
CENTER FOR MEDICAID AND STATE OPERATIONS

Medicaid At-a-Glance 2005

A Medicaid Information Source



- The Medicaid Program
- Key Eligibility Groups
- Mandatory State Plan Services
- State Chart
 - Optional Medicaid Plan Services
 - Federal/State Matching Rates for Services
- Federal Poverty Guidelines

CMS
CENTERS for MEDICARE & MEDICAID SERVICES

Subunit 1—A Risky Business
Alphabet Soup
LESSON 1.3

HEALTH SCIENCE

Time

90 minutes

Materials

Equipment

- Computers with access to the Internet
- Chart paper
- Markers

Resources

Insurance websites:

- Blue Cross of California (<http://www.bcchealthplans.com>)
- Aetna (<http://www.aetna.com>)
- United Healthcare (<http://www.uhc.com>)
- Cigna (<http://www.cigna.com>)
- American Medical Security (<http://www.eams.com>)
- Celtic Health Insurance (<http://www.celtic-net.com>)
- AIG (<http://www.aig.com/gateway/home>)
- Kaiser Permanente (<http://www.kaiserpermanente.com>)

Prior Student Learning

Students should have a working knowledge of healthcare terms from Lesson 1.1.

Essential Question for This Unit

How can we balance personal freedoms and society's need to provide accessible, affordable healthcare?

Objectives

After completing this lesson, students should be able to

- Locate healthcare providers on the Internet and analyze their vision, mission, and services.
- Compare different healthcare plans, services, and costs.
- Evaluate and critique the plans and recommend improvements.

Lesson Activities

Lesson Springboard

Tell students that over the next couple of days, they will be researching healthcare providers and comparing their plans. The intention is for students to begin to think about what creating their own insurance companies involves.

Lesson Development

Class Discussion

Based on their current understanding of health insurance, ask the class the following questions:

- What is important information to look for in analyzing healthcare providers?
- What might doctors look for when deciding whether to participate in a healthcare plan? What would potential customers look for?
- How might you find that information?

Internet Research

Provide students with an uninterrupted block of time to locate important healthcare information online. Decide whether you'd like students to work alone or in pairs. Then assign students to different healthcare providers. Have students work independently to locate insurance plans, premiums, deductibles, co-payments, etc., and have them record this information as they go. Also, students should note any slogans, missions, or visions.

Poster Session

Distribute two markers and a piece of chart paper to each inquiry group. Have students create a poster that includes the important facts about their insurance carrier. The posters should be clear and require little, if any, additional explanation. Display the posters around the room and tell students to circulate and look at each poster. If possible, bring the

posters to the ELA teacher so that he or she can begin the project in which students create an insurance company.

Lesson Closure

This final portion of the lesson should provide students with an opportunity to reflect on what they have learned and provide teachers with a means to assess the formal or informal learning that has taken place. Were students able to understand complex insurance information? What kinds of information sources were most and least informative? Why?

Possible Prior Misconceptions

Students will probably have very little prior knowledge about insurance companies. They may not be aware of how many different insurance providers there are in the market. And, they may believe that insurance companies all provide the same services.

Student Assessment Artifacts

Insurance Provider posters

Variations and Extensions

Have students brainstorm and suggest possible changes to the policies of the insurance provider they research.

Have students create portions of the Insurance Provider poster in another language in their foreign language course.

National and State Career and Technical Education Standards

NATIONAL

NCHSTE National Healthcare Skill Standards

Foundation Standard 3: Systems

Healthcare workers will understand how their role fits into their department, their organization and the overall healthcare environment. They will identify how key systems affect services they perform and quality of care.

3.2 Healthcare Delivery System

- 3.21 Construct a healthcare delivery system model
- 3.22 Predict where and how factors such as; cost, managed care, technology, an aging population, access to care, alternative therapies, and lifestyle/behavior changes may affect various healthcare delivery system models

CALIFORNIA

Health Sciences and Medical Technology Standards

10.0 Technical Knowledge and Skills

- 10.1 Understand the process for determining mission statements, goals, objectives, and strategic plans for a healthcare organization and understand the process for using appropriate policies, procedures, and processes as defined by the scope of practice of a specific healthcare organization.
- 10.2 Understand how the healthcare delivery systems models can be affected by cost, managed care, technology, an aging population, access to care, alternative therapies, and lifestyle and behavior changes.

Starting an Insurance Company

Part 1: The Vision

LESSON 1.4

ENGLISH LANGUAGE ARTS

Time

90 minutes

Materials

Equipment

- Drawing paper
- Markers and colored pencils

Resources

- Company missions from Lesson 1.3
- Insurance Provider posters from Lesson 1.3

Prior Student Learning

Students should understand the purpose and function of medical insurance companies.

Students should have completed Lesson 1.3 and be familiar with the missions, visions, slogans, and logos of at least two insurance companies.

Essential Question for This Unit

How can we balance personal freedoms and society's need to provide accessible, affordable healthcare?

Objectives

After completing this lesson, students should be able to

- Compare and contrast the missions of health insurance companies by synthesizing the content of documents.
- Use a variety of sources to analyze companies' approaches to marketing.
- Design an insurance company logo.
- Compose a slogan and a mission or vision statement for their insurance company.

Lesson Activities

Lesson Springboard

Introduce the day's project and the long-range plan of creating an insurance company. Have students compare the different insurance companies based on prior research. What do they notice about their approaches? How are they the same and different?

Lesson Development

Class Discussion

Focus on a couple of the more well-developed Insurance Provider posters created in Lesson 1.3. For each one, ask the following questions:

- Why do you think this team chose the logo they did? What does it mean? What would it mean to potential customers?
- What is their slogan? What do you think they mean by it? What are they hoping to achieve?
- What is their mission or vision? To whom are they targeting their services? Do their policies match their mission?

Direct Instruction

Tell students that in small groups, they will be creating their own insurance companies. For the remainder of the period, they will work on designing a logo and creating a slogan. After that, they will have an opportunity to look at vision statements and write their own.

Group Work

Students should have ample time to work on this project. While students work on specific tasks, as listed below, encourage them to participate in tangential discussions that address healthy behaviors and health insurance issues.

Starting an Insurance Company Part 1: The Vision

LESSON 1.4

Here are some suggestions for guiding students as they work in groups to create their own insurance companies:

- Divide students into groups. You may want to spend some time thinking about the best way to construct the groups, as this will be an ongoing project.
- Ask students to brainstorm what they want their logo to convey and then have them draft the logo.
- Similarly, ask students to create their own slogan.
- Once most of the groups have completed the first two tasks, distribute the sheet that displays the different insurance missions.
- Analyze the writing's purpose, structure, and style with the students.
- Direct students to specific items in the statements that you wish to teach.
- Give groups the remainder of the period to develop their vision.

Lesson Closure

Ask the groups to share their initial work with the class. Encourage students to ask the other groups the following questions:

- Why did you choose to do it that way?
- What exactly do you mean by that?

Possible Prior Misconceptions

Companies create logos based solely on what looks best.

Slogans need only be catchy to serve their purpose.

All insurance companies have the same mission and vision of care.

Student Assessment Artifacts

Health insurance company logo and name

Healthcare slogan

Insurance mission or vision statement

Variations and Extensions

Students can begin outlining specific healthcare plans for patients and drafting premiums based on their knowledge of existing insurance companies.

Starting an Insurance Company Part 1: The Vision

LESSON 1.4

National and State Academic Standards

NATIONAL

NCTE Standards for the English Language Arts

1. Students read a wide range of print and nonprint texts to build understanding of texts, of themselves, and of the cultures of the United States and the world; to acquire new information; and to respond to the needs and demands of society and the workplace; and for personal fulfillment. Among these texts are fiction and nonfiction, classic and contemporary works.
6. Students apply knowledge of language structure, language conventions, (e.g., spelling and punctuation) media techniques, figurative language, and genre, to create, critique, and discuss print and nonprint texts.

CALIFORNIA

English Language Arts Content Standards

Reading

- 2.1 Analyze the structure and format of functional workplace documents, including the graphics and headers, and explain how authors use the features to achieve their purpose.
- 2.4 Synthesize the content from several sources or works by a single author dealing with a single subject.

Knowing the Risks

SUBUNIT 2 OVERVIEW

Essential Question for This Unit

How can we balance personal freedoms and society's need to provide accessible, affordable healthcare?

Subunit Goals

In Subunit 2, students explore a variety of risks to good health that are considered by insurance companies. Students begin by learning about genetic risks, the predisposition for certain types of diseases or health issues that are coded in DNA. Students will apply their knowledge of genetics to predict the inheritance of traits using Punnett Squares and pedigree charts. Students will research various behaviors that place individuals at high risk and will also identify and explain preventative measures that can reduce an individual's health risks. Finally, students will learn to communicate this information by developing educational materials that address the information and communications needs of various audiences.

Subunit Key Questions

- How do genetics account for individual differences? (Biology)
- Why do I look like or different from my parents and siblings? (Biology)
- Are individuals destined to follow in their parents' footsteps healthwise? What factors are under individual control, and what factors cannot be manipulated? (Biology and Health Science)
- What can or should businesses do to promote health and wellness among their employees? (Health Science and English Language Arts)
- Why do rates of life expectancy and infant mortality differ in various parts of the world? (Spanish I)

Lesson Summaries

Lesson	Subject	Description
2.1	Biology	Investigating Inherited Traits Students investigate the interaction of dominant and recessive alleles in trait inheritance.
2.2	Biology	Predicting With Punnett Squares Students predict the ratio of genotype to phenotype in F1 and F2 generations using Mendel's Laws of Heredity.
2.3	Biology	Pedigree Charts Students analyze expressions of genetic disorders by interpreting pedigree charts.
2.4	Health Science	High-Risk Behaviors Students brainstorm behaviors that put individuals' health at risk. Students conduct research about these high-risk behaviors and discuss effective decision making.
2.5	English Language Arts	High-Risk Behaviors Workplace Brochure Students write and design documents intended to educate a workplace audience.
2.6	Spanish I	Impact of Environment and Society on Health and Wellness Students explore and evaluate public health and healthcare systems in other countries.

Investigating Inherited Traits

LESSON 2.1

BIOLOGY

Time

100 minutes

Materials

Equipment

- Pennies
- Colored Pencils

Resources

- Heredity PowerPoint presentation
- Investigating Inherited Traits Lab worksheet

Prior Student Learning

Students should have a basic understanding of the process of *meiosis*, the formation of *gametes*, and the union of gametes to produce a *zygote*.

Students should know that an individual's genetic makeup is inherited from his or her biological parents, and that each parent contributes half of an individual's genetic information.

Students should know that many (but not all) physical traits are determined by one's genetic makeup.

Essential Question for This Unit

How can we balance personal freedoms and society's need to provide accessible, affordable healthcare?

Objectives

After completing this lesson, students should be able to

- Explain the role of *genes* in inherited traits.
- Explain the role of *alleles* in variation of inherited traits.
- Identify the difference in expression of *dominant genes* vs. *recessive genes*.
- Identify dominant genes vs. recessive genes by inheritance patterns.
- Determine the *phenotype* of an individual based on their *genotype*, and predict the genotype of an individual based on their phenotype.

Lesson Activities

Lesson Springboard

Begin the class by asking students to describe what they know about physical traits. For example, what are the defining characteristics of a physical trait? What range of physical traits can be observed in the class population? Have students take a survey in their class on the variety of physical traits among students and calculate the relative percentage of common traits, including the following:

- Widow's peak vs. straight hairline
- Hitchhikers thumb vs. straight thumb
- Detached earlobe vs. free earlobe
- Tongue roller vs. a person who is not a tongue roller

Students should see that not all traits are distributed evenly in the class population. You may wish to have students speculate on whether or not a certain trait might have provided any kind of physical advantage.

Lesson Development

Direct Instruction

Begin instruction with the basic scientific background on heredity using the Heredity PowerPoint presentation provided or your own materials. Introduce genes as segments of DNA that contain hereditary information passed from parent to offspring. Introduce alleles as alternative forms of a gene, each coding for a different variant of a trait. The classic example of eye color in humans turns out to be coded by at least three separate genes for which there are at least three alleles (brown, blue, and

Support Strategy

Provide students with a copy of notes or an outline to facilitate note taking

Investigating Inherited Traits

LESSON 2.1

green). However, it is common to continue using the single-gene model in instruction (Brown/blue), or the two-gene model (Brown/blue, Green/blue). Be sure to cover at least the following information:

- Heredity and inheritance of traits, including the Principle of Segregation
- Genotype vs. phenotype
- Alleles
- Homozygous vs. heterozygous genotypes
- Dominant vs. recessive phenotypes
- Incomplete dominance
- Examples of inherited traits, including sex

Introduce Mendel’s deduction work with pea plants. Review the seven characteristics (flower color, flower position, seed color, seed shape, pod shape, pod color, and height) that Mendel studied through monohybrid crosses.

Lab Activity

Pass out the worksheet for the Investigating Inherited Traits Lab Activity and then group students into pairs. Tell students that in this investigation, they will observe how the results of different allele combinations produce a variety of physical traits in humans. Have students silently read the introduction and instructions for the lab. With their partner, instruct students to answer the pre-lab discussion questions before moving on. When they have answered these questions, ask one student to collect the materials.

Lesson Closure

If students have completed Step 8 of the lab activity, review the questions as a class and then collect the activity worksheet. If not, have students complete their “offspring” drawings and answer the questions for **homework**. Ask the class to summarize what they have learned about how recessive alleles can maintain a presence in a population.

The physical traits identified earlier in this lesson are all relatively innocuous. They affect appearance, but are not generally associated with larger health issues. Connect the content of this lesson to the unit’s Essential Question by asking students to consider some inherited traits that might be of concern for healthcare professionals.

Student Assessment Artifacts

Completed Investigating Inherited Traits Lab Activity worksheet
“Offspring” drawing

Possible Prior Misconceptions

Some students may believe that daughters inherit traits from their mothers, and sons inherit traits from their fathers.

Classroom Management
This activity can easily be done in the classroom, as no lab supplies are needed.

Investigating Inherited Traits

LESSON 2.1

Students may believe that only expressed traits are inheritable. This conception leads to difficulty in understanding recessive alleles and phenotypes.

Some students may believe that each trait is coded by only one gene. Simplifying the gene interaction for common traits, like eye color, can lead students to believe that their parents' genotypes could not have given rise to their own eye color. However, many traits (including eye color) are coded by several genes.

National and State Academic Standards

NATIONAL **NRC National Science Education Standards**

The Molecular Basis of Heredity

Most of the cells in a human contain two copies of each of 22 different chromosomes. In addition, there is a pair of chromosomes that determines sex: a female contains two X chromosomes and a male contains one X and one Y chromosome. Transmission of genetic information to offspring occurs through egg and sperm cells that contain only one representative from each chromosome pair. An egg and a sperm unite to form a new individual. The fact that the human body is formed from cells that contain two copies of each chromosome—and therefore two copies of each gene—explains many features of human heredity, such as how variations that are hidden in one generation can be expressed in the next.

CALIFORNIA **Health Sciences and Medical Technology Standards**

Biology/Life Science

2. Mutation and sexual reproduction lead to genetic variation in a population.
 - d. Students know new combinations of alleles may be generated in a zygote through the fusion of male and female gametes (fertilization).
 - e. Students know why approximately half of an individual's DNA sequence comes from each parent.
 - f. Students know the role of chromosomes in determining an individual's sex.
 - g. Students know how to predict possible combinations of alleles in a zygote from the genetic makeup of the parents.

Name _____ Date _____ Period _____

Investigating Inherited Traits Lab

Introduction

Heredity is the passing on of traits from parent to offspring. The genetic makeup of an individual is known as his or her *genotype*. The physical characteristics of an individual, which are the result of genotype and environment, are known as *phenotype*.

Most genes come in several different forms. These different forms are called *alleles*. For example, the gene for eye color has a blue allele, a brown allele, and a green allele. Every individual has two alleles for each gene, one inherited from the mother and one inherited from the father. If the alleles are the same kind, that genotype is considered *homozygous*. If the two alleles for a gene are different, the genotype is considered *heterozygous*.

Some alleles are expressed only when the genotype is homozygous. These alleles are said to produce recessive phenotypes. Alleles that are expressed whether the genotype is homozygous or heterozygous produce dominant phenotypes. An allele that codes for a dominant trait is represented by a capital letter (T), while an allele that codes for a recessive trait is represented by a lowercase letter (t). Sometimes when the genotype is heterozygous (Tt), neither the dominant nor the recessive phenotype occurs. In this situation, called *incomplete dominance*, an intermediate phenotype is produced.

In this investigation, you will simulate how genes and traits are passed from one generation to the next. You and your partner will use coin flips to determine which alleles are inherited from each parent.

Problem

How are traits inherited?

Materials

2 coins
Colored pencils

Pre-Lab Discussion: Read the entire investigation. Then, work with a partner to answer the following questions.

1. What does a single side of a double-sided coin represent?
2. What is the probability, in terms of percentages, that a single coin toss will result in heads? In tails?
3. Why is a coin toss a good way to represent allele combinations that occur in nature?
4. For the traits explored in this lab, do all heterozygous pairs of alleles produce an intermediate phenotype?

Name _____ Date _____ Period _____

Procedure

1. Pair up with your lab partner.
2. Determine which partner will toss for the “mother” and which will toss for the “father.” The genotype of both parents will be heterozygous for all genes.
3. Determine the sex of the offspring by having the partner representing the father flip a coin. Heads represents the X allele, and tails represents the Y allele. Record the results in the Data Table below. Remember, males have the XY genotype, and females have the XX genotype.
4. For all remaining trait coin tosses, heads represents the dominant allele and tails represents the recessive allele.
5. For each trait, both partners should flip a coin to determine which of their two alleles they will pass on to their offspring. (Each student will flip the coin once for each feature.) Genotypes and associated traits are shown below.

Genotypes and Associated Phenotypes

Trait	Genotype	Dominant Phenotype	Recessive Phenotype
Earlobes	E and e	Free earlobes	Attached earlobes
Dimples	D and d	Dimples	No dimples
Freckles	F and f	Freckles	No freckles
Eye Color	B and b	Brown	Blue
Hairline	W and w	Widow's peak	Straight
Hair color	H and h	Dark hair	Light hair
Hair type	C and c	Curly hair	Straight hair
Chin dimple	C and c	No chin dimple	Chin dimple
Face shape	R and r	Round	Square
Eye lashes	L and l	Long	Short
Lip thickness	T and t	Thick	Thin
Eye brows	B and b	Bushy	Fine

Incomplete Dominance Genotypes and Phenotypes

Trait	Genotype	Dominant	Incomplete	Recessive
Hair type	C and c	Curly	Wavy	Straight
Nose size	N and n	Big	Medium	Small
Eye size	S and s	Large	Medium	Small
Mouth size	L and l	Long	Medium	Short

6. Record the genotype for each trait in the Data Table.
7. Determine and record the phenotype for each trait in the Data Table.
8. Using the data from the table, draw a picture of your “offspring” on a piece of white paper. Use color and have fun!

Name _____ Date _____ Period _____

Data Table

Offspring Trait	Allele From Father	Allele From Mother	Genotype of Offspring	Phenotype of Offspring
Sex		X		
Earlobes				
Dimples				
Freckles				
Eye Color				
Hairline				
Hair color				
Hair type				
Chin dimple				
Face shape				
Eye lashes				
Lip thickness				
Eye brows				
Hair type				
Nose size				
Eye size				
Mouth size				

Questions

1. When determining the sex of the offspring, why did the “father” flip a coin, but not the “mother”?
2. Can you accurately determine an organism’s genotype by observing its phenotype? Explain your answer.
3. How many traits did your offspring share with you? How many were different?
4. Given that you and your “spouse” both had the same traits, explain how your offspring ended up with different traits.

Predicting With Punnett Squares

LESSON 2.2

BIOLOGY

Time

100 minutes

Materials

Equipment

- 2 cups per group
- Large bag of dark beans
- Large bag of light beans (any two different color beans are fine)
- Chart paper or overhead (for recording class data)

Resources

- Genetic Ratios Lab worksheet
- Punnett Squares Practice worksheet
- Blood Type Questions worksheet

Prior Student Learning

Students should know that each gene has two *alleles*.

Students should know that alleles are the form of a gene that is passed from parent to offspring.

Students should know that each parent contributes 50 percent of an individual's genetic makeup—i.e., for each gene, each parent contributes one allele to the offspring.

Students should be familiar with dominant and recessive alleles.

Essential Question for This Unit

How can we balance personal freedoms and society's need to provide accessible, affordable healthcare?

Objectives

After completing this lesson, students should be able to

- Calculate the probability of inheriting particular traits using *Punnett squares*.
- Show ratios for both *genotype* and *phenotype*.
- Relate dominant and recessive traits to real-life examples, such as blood typing.

Lesson Activities

Lesson Springboard

Remind students of the lab activity on Investigating Inherited Traits in Lesson 2.1. Ask students if they have ever been told that they take after one of their parents or one of their grandparents. Can they identify any specific traits they have inherited? Do they think that they will pass this trait on their own children? Do all their siblings share this trait? Tell students that today they will be learning to predict how often a trait will appear in the next generation.

Lesson Development

Lab Activity

Hand out the Genetic Ratios Lab worksheet. Review the different simulation scenarios with students. Briefly discuss what the beans represent and why they have been given differing numbers and colors of beans.

Assign each student to one of the three possible simulations and have them collect the appropriate materials:

- 2 heterozygous parents
- 1 heterozygous parent, 1 homozygous dominant parent
- 1 heterozygous parent, 1 homozygous recessive parent

Have students simulate the crossing of *F1* individuals and determine the ratios at which various

Support Strategy

Have students conduct the lab in pairs, rather than individually.

Classroom Management

To save time counting beans, have students scoop their materials from bins of homozygous and heterozygous bean mix.

Try to make sure the different colored beans are similar in size.

Predicting With Punnett Squares

LESSON 2.2

genotypes and phenotypes will appear in the F_2 generation by following the procedures listed on the worksheet.

While students are engaged in the activity, prepare space in the classroom for the following tables (overhead, chart paper, whiteboard):

Bb X Bb			
Student name	BB	Bb	bb
Total			

Bb X BB			
Student name	BB	Bb	bb
Total			

Bb X bb			
Student name	BB	Bb	bb
Total			

Tables will need more rows than shown above.

Each student will record the data from his or her activity in a row on the relevant table.

To answer the lab questions, students will use the class totals from the activity to calculate the approximate genotype and phenotype ratios (BB:Bb:bb and dark:light) from each of the crosses. Review the student calculations as a class and discuss their findings. Due to random variation, the genotype and phenotype ratios may not come out exactly as expected (e.g., 1:2:1). Be sure to re-examine this discrepancy after the Punnett Square instruction.

Classroom Management

This is a good place to take a break in the instruction. Assign the lab questions for **home-work** and restart the lesson in the next class session.

Direct Instruction

The results of the genetic cross simulation can also be illustrated using a Punnett square. Demonstrate the use of a Punnett square for the class by showing a simple one-gene model, like that for pea plant height. Compare the expected genotype ratio with the observed ratio from the Genetic Ratios lab worksheet. Discuss why expected and observed ratios are not always equal.

Predicting With Punnett Squares

LESSON 2.2

You may also present Mendel's dihybrid cross experiments at this time, along with his deduction of the *Principle of Independent Assortment*—"that each pair of alleles segregates independently of the other pairs during gamete formation." As a result, the inheritance of one characteristic has no effect on the inheritance of another; 4x4 Punnett squares can be used to illustrate dihybrid crosses.

Small Group Work

Pass out the Punnett Squares Practice worksheet. You may wish to model one or two additional examples. Have students solve the Punnett square problems in class to ensure that they understand them.

Direct Instruction

Introduce blood type as an example of an inherited trait that is important in the field of health science. Define the various human blood groups and describe the effect of mixing incompatible blood types and the impact on healthcare practices. Another important venue for blood typing is the Rh check during pregnancy. Most people are Rh positive. However, if the mother is Rh negative, and her baby is Rh positive, she will begin producing antibodies which will attack her baby's red blood cells. This can lead to complications to the baby including anemia, jaundice, and other blood related problems. Luckily, with detection, Rh incompatibility can be treated. Have students complete the Blood Type Questions worksheet for **homework**.

Lesson Closure

Ask students to consider how this lesson relates to insurance companies. What kinds of information can be learned from Punnett squares? Are Punnett squares completely predictive? How might this information be abused by insurance companies?

Possible Prior Misconceptions

Students may believe that traits that are not expressed by parents are never expressed by offspring—e.g., two brown-eyed parents cannot have a blue-eyed offspring.

Students may believe that there is always a 50% chance of inheriting a trait from a parent.

Student Assessment Artifacts

Completed Genetic Ratios Lab worksheet
Completed Punnett Squares Practice
Completed Blood Type Questions

Variations and Extensions

Have students predict their own blood type based on their parents' blood types. Using a blood typing kit, have students test their hypothesis and then determine which two blood type alleles each family member carries.

Predicting With Punnett Squares

LESSON 2.2

Have students conduct research and report on various genetic disorders. These could include sickle cell anemia, cystic fibrosis, Tay-Sachs disease, phenylketonuria, achondroplasia, hemophilia, Huntington's disease, and so on.

Introduce co-dominance and the interaction of multiple genes on a single trait.

Discuss the history of Mendel's pea plant experiments, including the statistical controversy surrounding the perhaps overly precise "goodness-of-fit" of Mendel's data.

National and State Academic Standards

NATIONAL **NRC National Science Education Standards**

The Molecular Basis of Heredity

Most of the cells in a human contain two copies of each of 22 different chromosomes. In addition, there is a pair of chromosomes that determines sex: a female contains two X chromosomes and a male contains one X and one Y chromosome. Transmission of genetic information to offspring occurs through egg and sperm cells that contain only one representative from each chromosome pair. An egg and a sperm unite to form a new individual. The fact that the human body is formed from cells that contain two copies of each chromosome—and therefore two copies of each gene—explains many features of human heredity, such as how variations that are hidden in one generation can be expressed in the next.

CALIFORNIA **Science Content Standards**

Biology/Life Science

2. Mutation and sexual reproduction lead to genetic variation in a population.
 - c. Students know how random chromosome segregation explains the probability that a particular allele will be in a gamete.
 - d. Students know new combinations of alleles may be generated in a zygote through the fusion of male and female gametes (fertilization).
 - e. Students know why approximately half of an individual's DNA sequence comes from each parent.
 - g. Students know how to predict possible combinations of alleles in a zygote from the genetic makeup of the parents.

Name _____ Date _____ Period _____

Genetic Ratios Lab

Introduction

If both your mom and dad have brown eyes, will you have brown eyes too? Not always. Your traits are determined by your genetic makeup, half of which is contributed by each one of your parents. The rules that govern genetic inheritance allow scientists to predict the probability that traits will be expressed in the next generation. In this lab, you will simulate a series of genetic crosses and use your results to estimate the probability of various genetic combinations.

Materials

2 cups
Light beans
Dark beans

Procedures

- Check off your assigned simulation scenario.
 - Simulation 1: Two heterozygous parents ($Bb \times Bb$)**
2 cups, each containing 20 light beans and 20 dark beans
 - Simulation 2: One heterozygous parent, one homozygous parent ($Bb \times BB$)**
1 cup containing 20 light beans and 20 dark beans
1 cup containing 40 dark beans
 - Simulation 3: One heterozygous parent, one homozygous parent ($Bb \times bb$)**
1 cup containing 20 light beans and 20 dark beans
1 cup containing 40 light beans
- Collect 2 cups and the appropriate number of beans based on the simulation you have been assigned from the supply table.
- Without looking into the cups, take one bean from each cup (parent). Record the color combination pulled from the cups by making a mark in the appropriate column of the data table: BB for two dark beans, Bb for one of each color, and bb for two light beans. **Return each bean to the cup from which it was taken.**
- Repeat Step 3, taking beans from each cup, recording each combination, and returning the beans to their cups, until you have **25** combinations recorded.
- Add the marks in each column and record your totals in the appropriate row of the data table.

Data Table

BB	Bb	bb
Total number _____	Total number _____	Total number _____

Name _____ Date _____ Period _____

4. What is the dominant bean color? What is the recessive bean color? How do you know?

5. What would happen to the ratios if there were more white beans in each cup?

Name _____ Date _____ Period _____

Punnett Squares Practice

- Two pea plants reproduce and have offspring. The first plant has purple flowers and is heterozygous (Ff). The second plant has white flowers and is homozygous recessive (ff). Purple is dominant to white in pea plants. **What chance do the offspring have of being purple? White? What is the Phenotypic ratio? The Genotypic Ratio?**

- Two pea plants reproduce and have offspring. The first plant has green peas and is homozygous recessive (yy). The second plant has yellow peas and is homozygous (YY). Yellow is dominant to green in pea color. **What chance do the offspring have of having green peas? Yellow peas? What is the Phenotypic ratio? The Genotypic Ratio?**

- Two pea plants reproduce and have offspring. Both plants are short. Tall is dominant to short in pea plant height. **What chance do the offspring have of being tall? Short? What is the Phenotypic ratio? The Genotypic Ratio?**

- Two rats reproduce and have offspring. Rats either have black eyes or red eyes. Black is dominant to red in rats. Both rats are heterozygous for eye color. What color eyes do the parents have? **What color eyes do the parents have? What chance do the offspring have of having black eyes? Red eyes? What is the Phenotypic ratio? The Genotypic Ratio?**

- Two people who are heterozygous for eye color (Bb) have brown eyes. Brown eyes are dominant to blue eyes. They reproduce and have two offspring. Both children have blue eyes. **Is this possible? Explain your reasoning.**

Name _____ Date _____ Period _____

Blood Type Questions

Blood Group	ABO Antigens	Blood That CANNOT be Received	Blood That CAN be Received
AB	A and B	None	A, B, AB, O Universal recipient
B	B	A, AB	B, O
A	A	B, AB	A, O
O	None	A, B, AB	O Universal donor

Each biological parent donates one of their two ABO alleles to their child. For example, a mother who is blood type O can only pass an O allele to her son or daughter. A father who is blood type AB can pass either an A or a B allele to his son or daughter.

Example:

Mom is blood type O.

Dad is blood type AB.

What are the chances that the offspring will be type B?

Solution:

Set up a Punnett square:

Count the number of offspring with blood type B: there are two out of four.

Two out of four = $2/4 = 1/2 = 50\%$ **probability** of having children with blood type B.

Name _____ Date _____ Period _____

Practice Problems

1. The mother of a baby has blood type AB. The father's blood type is O. What are the chances that their offspring will be blood type A?
2. Both the mother and the father of a baby have blood type AB. What are the possible blood types of their baby?
3. A baby boy has blood type A. His mother has blood type AB. What are the possible blood types of the father?
4. Ms. Pratt is claiming that Mr. X is the father of her child. Ms. Pratt's blood type is O. Her baby boy has type A blood. Mr. X's blood is typed and found to be B. Could he be the father of her child?
5. Two babies are believed to have been swapped at birth in error. Blood samples were taken from each of the parents and babies. The following results were obtained from the blood samples:

Family 1:	Mom = type B
	Dad = type O
	Baby = type A
Family 2:	Mom = type O
	Dad = type A
	Baby = type O

Are the babies with the correct biological parents?

Name _____ Date _____ Period _____

6. A patient needs a blood transfusion. She has blood type A. What blood types can she accept?

7. Why is blood type O considered to be the “universal donor”?

8. Mr. Smith’s blood was determined to be AB positive. What does this mean?

- a. Antibodies to A and B are present in the red cells.
- b. There are no antibodies to A, B, or Rh antigens in the plasma.
- c. His blood lacks the Rh factor.
- d. All of the above are correct.

9. An individual who is blood type AB negative

- a. Can receive any blood type in moderate amounts except that with the Rh antigen.
- b. Can donate to all blood types in moderate amounts.
- c. Can receive types A, B, and AB, but not type O.
- d. Can donate to types A, B, and AB, but not type O.

Subunit 2—Knowing the Risks

Pedigree Charts

LESSON 2.3

BIOLOGY

Time

100 minutes

Materials

Equipment

Colored pencils

Resources

- Muscular Dystrophy Pedigree Chart assignment (<http://www.glc.k12.ga.us/builderv03/LPTools/LPShared/attach-display.asp?attachID=80091>)
- Muscular Dystrophy Pedigree Chart Answer Key (<http://www.glc.k12.ga.us/builderv03/LPTools/LPShared/attach-display.asp?attachID=82178>)
- Risk Analysis activity (<http://gslc.genetics.utah.edu/units/health/Pick%20the%20Risk.pdf>)
- Family Pedigree Construction worksheet
- Pedigree Chart Practice Questions worksheet
- Family histories of potential insurance “clients”

Prior Student Learning

Students should have a basic understanding of genes, inherited traits, and Mendel’s Laws.

Students should have a basic understanding of dominant and recessive alleles.

Essential Question for This Unit

How can we balance personal freedoms and society’s need to provide accessible, affordable healthcare?

Objectives

After completing this lesson, students should be able to

- Recognize *pedigree charts* and the meanings of symbols on these charts.
- Use pedigree charts to determine the characteristics of certain genetic disorders.
- Predict an individual’s likelihood of inheriting a genetic disorder based on his or her pedigree chart.
- Create a pedigree chart from a narrative family history.

Lesson Activities

Teacher Preparation

At the end of this lesson, students will construct a pedigree chart for one of their high-risk “insurance applicants.” Ask your fellow teachers to create profiles for these fictitious applicants using the Medical Insurance Questionnaire at the end of Lesson 3.5. You will need to create family histories for each of the clients that the students select as high-risk.

Lesson Springboard

Begin by asking students if they have ever made a family tree. You may wish to have students sketch a quick version of their family tree or display a copy of your own family tree. Why do people make family trees? What kinds of information are included in a family tree? Tell students that geneticists also make specialized family trees.

Lesson Development

Direct Instruction

Define a pedigree chart as the genetic history of a family over several generations. Explain the function of a pedigree chart and demonstrate how to construct one. Scientists and/or genetic counselors use pedigree charts to analyze the Mendelian inheritance of certain traits, usually genetic disorders. Charts are constructed with a variety of symbols used to represent gender, familial relationships, and characteristics of the genes of interest.

Explain and model how to interpret a pedigree chart. A typical analysis includes determining the pattern and characteristics of a trait, including its mode of inheritance (e.g., autosomal or X-linked, dominant, or recessive), age of onset, and phenotypic variability.

Subunit 2—Knowing the Risks
Pedigree Charts

LESSON 2.3

Sample Problems

Pass out the following pedigree story for the Smith family and ask students to practice constructing and interpreting the pedigree chart for this family with a hereditary disorder.

Grandma and Grandpa Smith were married in 1903. They had four children: Elizabeth, Fred, Michelle, and Mickey.

Elizabeth fell in love at a young age and married David in 1924. Their two children, John and Sonny, soon followed. Elizabeth's brother, Fred, waited many years to marry, but did so in 1946. Because of their late start, he and his wife, Wilma, had only one son, Barney. Michelle had a fulfilling career, but never found time for marriage or children. Mickey, the baby of the family, had many girlfriends but settled on Monica. They had two beautiful girls, Krista and Janet.

Alzheimer's is the genetic disorder that plagued the Smith family. Grandma Smith developed it 1948 and so did Fred and Michelle. Most of the grandchildren were spared, but unfortunately, both of Mickey's girls developed Alzheimer's. Students should end up with the chart below:

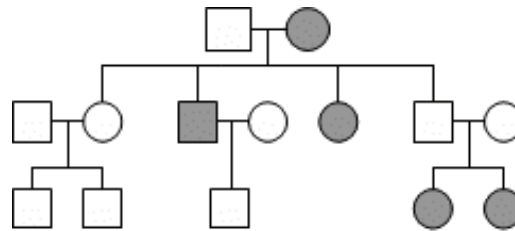

Based on the pedigree chart, what can be concluded about Alzheimer's disease? Is it X-linked or autosomal? Is it dominant or recessive? Can any of the grandchildren be ruled out as carriers? Why or why not?

Pass out the Muscular Dystrophy Pedigree Chart assignment. Have students begin the assignment in class and complete it as **homework**.

Class Discussion

Review the answers to the Muscular Dystrophy Pedigree Chart as a class. Inform the class that muscular dystrophies are actually a group of at least 30 different genetic diseases, all of which are characterized by progressive degeneration of the skeletal muscles. Many genetic disorders are rare, like cystic fibrosis, a single gene disease that affects approximately 1 in 10,000 people.

Compare these disorders with the prevalence of a common health problem like heart disease, which affects 1 in 3 people. These common diseases also have a genetic component and run in families, but are usually the result of the combined effects of multiple genes and environmental factors. Because more than one gene is involved, the resulting inheri-

Subunit 2—Knowing the Risks
Pedigree Charts

LESSON 2.3

tance patterns are more complex and can be more difficult to predict. Pedigree charts can be used to estimate an individual's genetic risk.

Small Group Work

Hand out the instructions for the Risk Analysis Pedigree activity. Group students in pairs and have them construct a family pedigree following six genes that contribute to a single disease. Students can then answer the questions at the end of the worksheet.

Discuss with class how this activity differs from real life:

- The number of genes contributing to a common disease is often unknown.
- The number of at-risk genes actually carried by parents or offspring is usually unknown.
- Environmental factors can also influence an individual's risk of developing certain diseases.

Inheritance patterns can be difficult to predict because so many factors can influence the development of a disease. Genetic factors may determine initial susceptibility, but behavioral choices can substantially reduce or increase your risk. Even those at high risk for disease can take preventative steps. After gathering all this information, individuals are often placed in loosely grouped categories representing their probability for developing a disease.

Lesson Closure

Pass out the family histories of potential insurance “clients.” Tell students that they will be determining whether to insure their fictional applicant, and what insurance rates to charge. Have students construct a pedigree chart for their potential “client.” Using this chart, they will interpret the nature of the family's genetic disorder, if any, and estimate the client's risk for developing a disease.

Possible Prior Misconceptions

Some students may believe that genetic disorders are always passed by gender—i.e., mother to daughter or father to son. Alternatively, some students may believe that gender has nothing to do with the inheritance of diseases.

Some students may believe that only individuals with expressed genetic disorders can pass them on to their offspring.

Student Assessment Artifacts

Muscular Dystrophy Pedigree Chart assignment
Pedigree Chart of insurance “client”

Variations and Extensions

Invite a genetic counselor to speak to the class about genetic testing issues.

If students conducted research on genetic disorders suggested in the extension in Lesson 2.2, they may research the history of a notable family with a genetic disorder and create a pedigree chart for that family.

National and State Academic Standards

NATIONAL NRC National Science Education Standards

The Molecular Basis of Heredity

Most of the cells in a human contain two copies of each of 22 different chromosomes. In addition, there is a pair of chromosomes that determines sex: a female contains two X chromosomes and a male contains one X and one Y chromosome. Transmission of genetic information to offspring occurs through egg and sperm cells that contain only one representative from each chromosome pair. An egg and a sperm unite to form a new individual. The fact that the human body is formed from cells that contain two copies of each chromosome—and therefore two copies of each gene—explains many features of human heredity, such as how variations that are hidden in one generation can be expressed in the next.

CALIFORNIA Science Content Standards

Biology/Life Science

2. Mutation and sexual reproduction lead to genetic variation in a population.
 - d. Students know new combinations of alleles may be generated in a zygote through the fusion of male and female gametes (fertilization).
 - e. Students know why approximately half of an individual's DNA sequence comes from each parent.
 - f. Students know the role of chromosomes in determining an individual's sex.
 - g. Students know how to predict possible combinations of alleles in a zygote from the genetic makeup of the parents.

Name _____ Date _____ Period _____

Family Pedigree Construction

- Using Scotch tape, tape three pieces of white paper together end-to-end as shown below. The tape will be on the back side.



- Fold the taped paper into three equal horizontal sections.

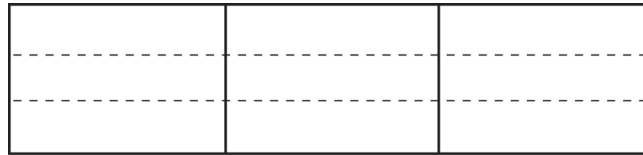

- Draw the family pedigree for your insurance client with each generation of the family in a different horizontal section. Use plastic cups as a stencil for circles and use a ruler to make the squares. Remember: “maternal side” means all family members on the mother’s side, and “paternal side” means all family members on the father’s side.

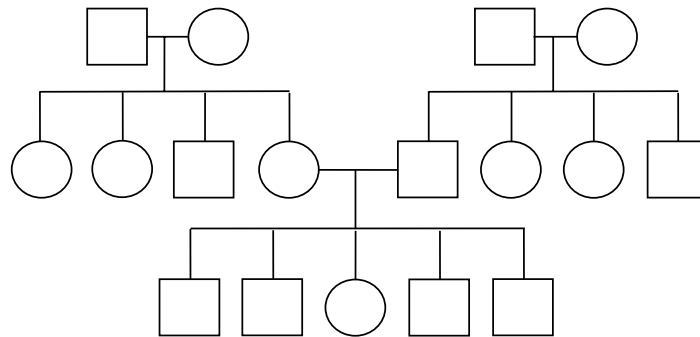

- Don’t forget to write the relationship of each person to the client (“brother,” “mother,” “grandfather,” etc.).



Name _____ Date _____ Period _____

5. Make a key in the bottom corner of your pedigree chart. Be sure to include labels for both diseases/disorders that you will be illustrating.

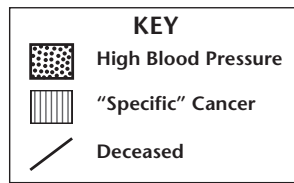

6. Now draw/color the diseases/disorders that are found in the appropriate family members.



7. Draw a slash line through the family members who are deceased.

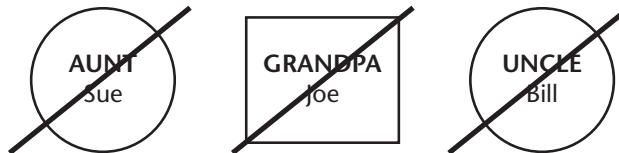

8. Provide a title for your pedigree chart.

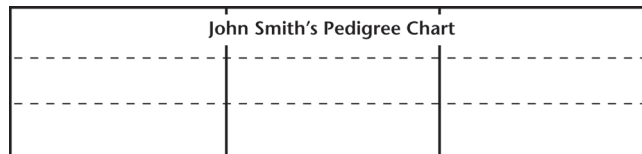

9. Draw a Roman numeral "I" next to the top generation, a Roman numeral "II" next to the middle generation, and a Roman numeral "III" next to the bottom generation.

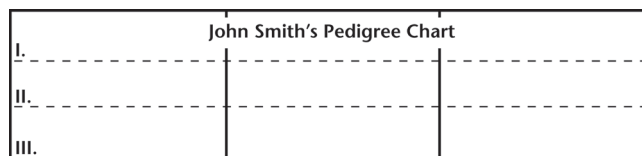

10. Make sure your name is on the back.



Name _____ Date _____ Period _____

Pedigree Chart Practice Questions

- Hemophilia is an X-linked recessive genetic disease. The normal allele (H) is dominant to the affected (h).
 - What are parental genotypes in the six possible pairings?
 - In which of these pairings are **all daughters carriers**?
 - A couple has an affected daughter and an unaffected son. What are the parental genotypes?
- Based on the pedigree chart below, what is the most likely mode of inheritance for this disease? How do you know?

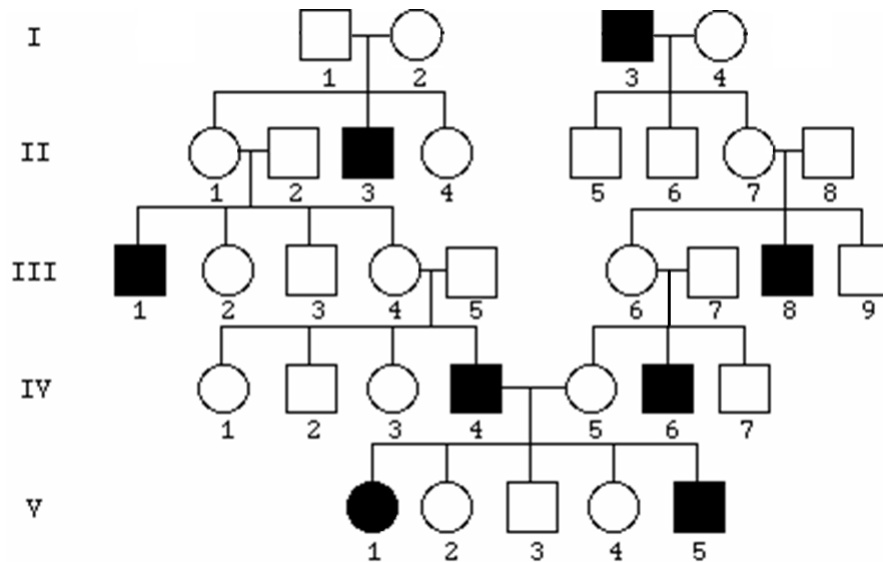

Subunit 2—Knowing the Risks

High-Risk Behaviors

LESSON 2.4

HEALTH SCIENCE

Time

50 minutes

Materials

Access to Internet-capable computer lab and/or library

Prior Student Learning

Students should be familiar with the library and Internet research skills.

Essential Question for This Unit

How can we balance personal freedoms and society's need to provide accessible, affordable healthcare?

Objectives

After completing this lesson, students should be able to

- Compile and interpret information from multimedia resources on high-risk behaviors.
- Describe ways to prevent or reduce negative outcomes from high-risk behaviors.

Lesson Activities

Lesson Springboard

Remind students about the health risk factors they have studied in Biology. Although individuals have no control over their genetic heritage, their choices and behavior can be key to maintaining their health. Begin with a class discussion about high-risk behaviors. Ask students to consider the following questions:

- What defines a behavior as “high-risk”? Is high-risk behavior objective or subjective?
- What behaviors do students engage in that might be considered high-risk?
- What motivates individuals to engage in high-risk behaviors?
- Should the decision to engage in high-risk behaviors always be a personal one? Does anyone else have a say? Should they? Who else can be affected by an individual's high-risk behaviors? Provide some real-life examples. For example, employers often (attempt) to curtail the personal activities of professional athletes and movie stars—e.g., Pittsburgh Steelers quarterback Ben Roethlisberger's motorcycle accident incident produced this kind of response (<http://www.thepittsburghchannel.com/sports/4494368/detail.html>).
- How is the decision to engage in high-risk behavior relevant to insurance companies?

Lesson Development

Research Project

Tell students that they will be writing and producing a brochure suitable for the workplace on a specific risky behavior in Language Arts (Lesson 2.5). In this lesson, they will be conducting the research on risky behaviors that will be used to create their brochures.

Classroom Management

Visit potential research sites beforehand to make sure access is not restricted. Try to arrange for a maximum of two students per computer.

Subunit 2—Knowing the Risks
High-Risk Behaviors

LESSON 2.4

Support Strategy
Provide a list of appropriate websites for students who have trouble finding appropriate information.

In Lesson 2.3, students should have received a profile of a high-risk individual; any students who have not received this profile should get one. Have students share some of the risky behaviors listed in their client histories. As mentioned above, students will be asked to write a brochure about the behavior in which their own client engages in Lesson 2.5.

As part of their research on their assigned behavior, students should seek such information as descriptions of the behavior; common motivations; common dangers; statistics on mortality, injuries, or other health implications; and suggestions for avoiding or mitigating risk.

Review some online research strategies with students. Provide them with sufficient time in the computer lab (or library) to research the assignments on their topic. You may choose to allow additional days for research or assign the completion of research as **homework**.

Lesson Closure

Invite a few students to share unexpected information from their research efforts. For example, were students surprised by the number of injuries that resulted from any of the behaviors? Were they expecting greater or fewer injuries? Remind students that they will be using this information to complete their workplace brochure in English Language Arts (Lesson 2.5).

Possible Prior Misconceptions

Students may believe that adults are free from personal behavior restrictions. Some students may believe that personal decisions to engage in high-risk behaviors do not affect anyone else.

Student Assessment Artifacts

Researched information on high-risk behaviors

Variations and Extensions

The project format is flexible. Students can create a PowerPoint presentation, posters, or brochures, make a website, or write skits as alternatives to working with the Fact Sheet. This may be a good opportunity to introduce or have them practice a new software application.

You may wish to have students make a presentation along with producing their written artifact.

National and State Academic Standards

NATIONAL

NCTE Standards for the English Language Arts

7. Students conduct research on issues and interests by generating ideas and questions, and by posing problems. They gather, evaluate, and synthesize data from a variety of sources (e.g., print and non-print texts, artifacts, people) to communicate their discoveries in ways that suit their purpose and audience.

CALIFORNIA

English Language Arts Content Standards

Reading

- 2.4 Synthesize the content from several sources or works by a single author dealing with a single issue; paraphrase the ideas and connect them to other sources and related topics to demonstrate comprehension.
- 2.5 Extend ideas presented in primary or secondary sources through original analysis, evaluation, and elaboration.

Writing

- 1.5 Synthesize information from multiple sources and identify complexities and discrepancies in the information and the different perspectives found in each medium (e.g., almanacs, microfiche, news sources, in-depth field studies, speeches, journals, technical documents).
- 1.8 Design and publish documents by using advanced publishing software and graphic programs.

High-Risk Behaviors Workplace Brochure

LESSON 2.5

ENGLISH LANGUAGE ARTS

Time

90 minutes

Materials

Equipment

Access to computers loaded with Microsoft Publisher (or other graphic design program)

Resources

Guidelines for Creating a “Workplace” Document

Prior Student Learning

Students need to have completed Lessons 1.1–1.4 before starting this activity, including starting an insurance company in English Language Arts.

Students need to have completed their high-risk behavior research in Lesson 2.4 before starting this lesson. If they did not, that research needs to be done here.

Students need experience with MS Publisher or other software in order to layout their brochure.

Essential Question for This Unit

How can we balance personal freedoms and society’s need to provide accessible, affordable healthcare?

Objectives

After completing this lesson, students should be able to

- Conduct research on specific questions and synthesize information from a variety of sources.
- Format an informational brochure in MS Publisher suitable for a workplace, including graphics and headings that provide structure for the reader.
- Compose text based on research findings for a workplace audience.

Lesson Activities

Lesson Springboard

Invite a guest speaker or speakers to your class; this activity is optional but recommended. Ask a copyeditor and/or graphic designer to discuss how workplace documents are created. In this presentation, emphasize the need to write clearly and concisely and to communicate information that is targeted toward a specific audience.

Lesson Development

Class Session 1

Hand out the Guidelines for Creating a “Workplace” Document. This information sheet can be used to illustrate the components that are required for writing the brochure in this assignment. Discuss each element of the brochure with the class.

Ask the students to use the information they gathered from their research in Lesson 2.4 (Health Science) and collaborate to decide which information they will use for their “high-risk brochure.” List the generic categories of information that students might use on the board. Or, ask students to brainstorm, discuss, and volunteer the categories themselves.

Have students create a prototype of a brochure in class before reproducing it on the computer. Collect all rough drafts of the brochures and edit them as necessary.

Class Session 2

Return the draft brochures to the students. Give students a few minutes to review any edits you may have suggested.

Return to the computer lab and tell students to enter all their information in an electronic document. You may wish to take this opportunity

High-Risk Behaviors Workplace Brochure

LESSON 2.5

to teach or review formatting with a publishing or layout program like MS Publisher. If not, the students can produce the brochures using a standard word-processing program such as MS Word.

Monitor the writing and formatting of the brochures as students type them. After students complete their brochures, they will e-mail them to the teacher. These brochures may be used as part of the culminating project for the unit.

Lesson Closure

Have students exchange and review each other's brochures.

Possible Prior Misconceptions

Students may believe that appropriate writing styles are independent of the document's purpose and intended audience.

Some students may believe that the text is the only important aspect of a document and that appropriate layout and attractive appearance are extraneous.

Student Assessment Artifacts

High-Risk Behaviors Workplace Brochure

Variations and Extensions

Students can also design a brochure on the consequences of high-risk behaviors that would be appropriate for high school, middle school, or elementary school audiences.

Students in foreign language classes can translate one of their brochures into those languages.

Students can discuss their draft brochures with parents or other adults, share adults' reactions to the brochure with the class, and incorporate those reactions into the final version.

High-Risk Behaviors Workplace Brochure

LESSON 2.5

National and State Academic Standards

NATIONAL

NCTE Standards for the English Language Arts

4. Students adjust their use of spoken, written, and visual language (e.g., conventions, style, vocabulary) to communicate effectively with a variety of audiences and for different purposes.
5. Students employ a wide range of strategies as they write and use different writing process elements appropriately to communicate with different audiences for a variety of purposes.
6. Students apply knowledge of language structure, language conventions (e.g., spelling and punctuation), media techniques, figurative language, and genre to create, critique, and discuss print and non-print texts.
7. Students conduct research on issues and interests by generating ideas and questions, and by posing problems. They gather, evaluate, and synthesize data from a variety of sources (e.g., print and non-print texts, artifacts, people) to communicate their discoveries in ways that suit their purpose and audience.

CALIFORNIA

English Language Arts Content Standards

Reading

- 2.1 Analyze the structure and format of functional workplace documents, including the graphics and headers, and explain how authors use the features to achieve their purposes.
- 2.3 Generate relevant questions about readings on issues that can be researched.
- 2.4 Synthesize the content from several sources or works by a single author dealing with a single issue; paraphrase the ideas and connect them to other sources and related topics to demonstrate comprehension.

Writing

- 1.5 Synthesize information from multiple sources and identify complexities and discrepancies in the information and the different perspectives found in each medium (e.g., almanacs, microfiche, news sources, in-depth field studies, speeches, journals, technical documents).

Name _____ Date _____ Period _____

Guidelines for Creating a “Workplace” Document

Workplace documents are printed or electronic texts that are designed to provide information to a particular audience. These documents can take the form of a flyer to promote a dance, a brochure that tells about a summer camp, owners’ manuals, employee handbooks, ads, commercials, or even a website.

There are many things that need to be considered when composing an effective document:

The **visual layout** is important—usually an uncluttered, organized layout is the most effective. The layout should also include some space between the different **elements** (pictures, text, charts) of the text. **Titles, headings, and subheadings** should have appropriate font size and style. Titles should be the largest; headings should be smaller than the title; and subheadings should be smaller than headings, but larger, or bolder than the text of your paragraphs. Although all headings should have the same **font size**, they may have different **font styles**—but don’t go crazy with fonts; that is, don’t use too many different font types and make sure that your audience can read them. The effective use of **color** is an art and should further the purpose of your document. Be careful not to overpower your audience with an excessive variety of color. Use color to make connections and help the reader. For example, you might have a light color background, green headings, and purple subheadings.

The **text** of your paragraphs should be easy to read. You should not use too many different font types, and unless you are trying to make something stand out, all of the font styles under a heading should be the same.

Information can be organized in a **table of contents**. If the document is large, as in a book, there should be a table of contents so that readers can easily find the information they want. If the document is small, you can use an **index** instead, which is essentially the same thing as a table of contents.

There are five ways to provide graphical information:

- **Pictures:** A good picture can be worth a thousand words—but you must make sure that the story that you want to tell is also described in text. Don’t expect the pictures to do all of the work.
- **Maps:** A good map is essential if you want to give directions.
- **Charts or graphs:** If you want to explain mathematical concepts or information, use a chart or graph that best portrays the numerical information in your text.
- A **bulleted list** is used to summarize information.
- A **numbered list** is used to give directions or to put information in an order of importance.

A good workplace document will contain all of the appropriate **contact information**. Contact information may include any of the following: **names** of people, and their titles or job description; **phone numbers** with area codes; **website** addresses (URLs); e-mail addresses; and **street addresses**, with state, city, street, zip code. If you are creating a document for a business you should always include your contact information.

There are a number of **organizational methods** that you can use to present your information:

- Begin with a general introduction and then move to specific information.
- Begin with questions and then give the answers.
- First describe an item, and then explain how it is used or what its purpose is.
- Begin with the original history of something or place, and then tell how it has changed over time.

Impact of Environment and Society on Health and Wellness

LESSON 2.6

SPANISH I

Time

120 minutes

Materials

Equipment

Computer lab with Internet access

Resources

- Websites for students to use in their research:
 - <http://www.worldpress.org/profiles/Mexico.cfm>
 - <https://www.cia.gov/library/publications/the-world-factbook>
 - http://www.ncbi.nlm.nih.gov/entrez/query.fcgi?cmd=Retrieve&db=PubMed&dopt=Abstract&list_uids=10673193
 - <http://www.country-data.com>
 - <http://www.cdc.gov/nchs/pressroom/06facts/06facts.htm>
- Library resources, where available
- Country Culture Project handout

Prior Student Learning

This project works best when students are doing cultural projects related to a selected Spanish-speaking country as part of the regular curriculum.

Students should have a basic understanding of the culture of their selected country.

Essential Question for This Unit

How can we balance personal freedoms and society's need to provide accessible, affordable healthcare?

Objectives

After completing this lesson, students should be able to

- Report the demographic data of a Spanish-speaking country.
- Explain the impact of culture, government, and environment on the health and wellness of the population.
- Compare the system of government and associated healthcare system of another nation to the United States.

Lesson Activities

Lesson Springboard

Connect this lesson to the topic of health insurance by asking students to discuss prescription drug purchases in Mexico.

- What is the issue? Why are some Americans choosing not to obtain their prescription drugs in the United States?
- How can drugs that are available only by prescription in the United States be sold over-the-counter (OTC) in Mexico or some other countries?
- How does the cost of medication in Mexico compare to the price in the United States? Why are they different?
- What are the risks of buying medication in Mexico? Why do some people choose to take that risk? Is it worth it?

Lesson Development

Research Project

Pass out the Country Culture Project handout. Assign or allow students to select a Spanish-speaking country. Have students research the health statistics, common health concerns, and various types of healthcare available in their selected countries.

Allow students one class session in the computer lab or library to conduct their research. You may choose to have additional days for research, or students may complete their research as **homework**. Students will report the results of their research on healthcare options in a classroom presentation.

Student Presentations

Have students deliver 5- to 7-minute presentations on the healthcare available in their selected country.

Impact of Environment and Society on Health and Wellness

LESSON 2.6

Lesson Closure

Have students compare the availability and cost of healthcare in the United States versus those in the countries presented.

Possible Prior Misconceptions

Students may believe that all countries have similar health, mortality, and regulatory environments and issues as the United States.

Students may believe that all countries have similar healthcare systems as the United States.

Student Assessment Artifacts

Individual student presentations

Variations and Extensions

Students can conduct more in-depth research and analysis of the healthcare systems in various countries.

Students can conduct additional research on the primary health concerns in their chosen country.

As an alternative to individual presentations, some students can play the role of the presidents and other students can act as expert advisory panels recommending adoption of a new healthcare system in the countries they have researched.

National and State Academic Standards

NATIONAL

ACTFL Standards for Foreign Language Learning

Cultures

Gain Knowledge and Understanding of Other Cultures

2.1 Students demonstrate an understanding of the relationship between the practices and perspectives of the culture studied.

Connections

Connect with Other Disciplines and Acquire Information

3.2 Students acquire information and recognize the distinctive viewpoints that are only available through the foreign language and its cultures.

Comparisons

Develop Insight into the Nature of Language and Culture

4.2 Students demonstrate understanding of the concept of culture through comparisons of the cultures studied and their own.

CALIFORNIA

California has no academic standards for foreign language at this time.

Name _____ Date _____ Period _____

Country Culture Project

When you are doing the research for your classroom presentation, please answer all of the following questions. Please include all of this information on your poster, but limit your wording to subtitles with pictures. (Additional descriptive information should be included in the oral part of your presentation.)

General Cultural Information. (Most of this can be found by doing a search on www.google.com or on websites that offer information about the country you are researching.)

- What is the official language? Are there any other languages that are widely spoken?
- What is the official population size?
- What is the official religion, if any? What are the less widespread religions?
- What is their currency (money)?
- Where is this country located (include a map)?
- Describe the importance/history of their flag, colors, etc. (include a picture).
- What are some of their main imports and exports?
- What are some of their traditions/customs/fiestas (include 2–3 pictures)?

General Health Questions. (Refer back to the definitions of mortality and life expectancy from your Health Science class.)

- What is the average life expectancy?
- What is the Infant Mortality Rate?
- What are the most common health problems faced by the population?
- What do most adults die from?
- What do most children and teens die from?

Social Services and Government Programs. (Research the following questions by looking up key phrases such as *healthcare benefits*, *insurance programs*, *social security*, and *government-sponsored programs*.)

- Are there social programs that help pay for medical care?
- What government-sponsored programs help pay for health insurance or medical care?
- What is the ratio of physicians to patients?
- Can most people afford good preventative care and catastrophic care?
- Are there maternity benefits? If so what are they?
- Is there free vaccination or other childcare programs for the poor?

Making Decisions

SUBUNIT 3 OVERVIEW

Essential Question for This Unit

How can we balance personal freedoms and society's need to provide accessible, affordable healthcare?

Subunit Goals

In Subunit 3, students explore insurance company decisions to provide or deny health insurance coverage. They will learn that consumers have varying insurance needs. They will also understand that health insurance decisions can be tailored to life situations by examining insurance policies and conducting a simulation to determine which policies are best suited for different consumer situations. Students will make calculations that simulate how insurance providers determine the premiums they charge clients in order to match various levels of services. In addition, students will review and design strategies that employers and insurance companies can use to reduce their own risk and consumer costs by improving the health of their employees or clients. Finally, students will evaluate a set of insurance applicants based on their knowledge of each individual's risk factors, make decisions to extend or deny insurance coverage, and write formal business letters informing the "applicants" of their decisions.

Subunit Key Questions

- How do insurance policies differ in their coverage? How can you decide which policy is the best for your situation? (Health Science)
- What is the link between high-risk health factors/behaviors and illness or death rates? How can this information be used by insurance companies in planning their policies? (Algebra I)
- How do health insurance companies calculate appropriate costs for providing insurance coverage? (Algebra I)
- What can employers do to improve employee health and reduce insurance costs? (Physical Education)
- What factors do insurance companies consider when choosing clients? (Health Science and English Language Arts)
- What is the proper format to communicate with business clients? (English Language Arts)

Lesson Summaries

Lesson	Subject	Description
3.1	Health Science	Starting an Insurance Company Part 2: The Policies Students review the coverage provided by different policies and the impact on consumer spending. They observe the impact of different policies when faced with similar health events in an insurance simulation game. Students use this information to write policies for their own insurance companies.
3.2	Algebra I	Dice With Death: Probability in Mortality Tables Students analyze mortality tables and examine data to draw correlations between certain high-risk behaviors and mortality.
3.3	Algebra I	Medical Coverage Choices Students make and justify real-world healthcare decisions by modeling situations using linear graphing.
3.4	Physical Education	Designing a Wellness Program Students examine wellness programs as a model to encourage improved health in potential clients or employees. Students design Wellness Plans for different target audiences.
3.5	English Language Arts	Starting an Insurance Company Part 3: Choosing Clients Students complete the unit by evaluating a set of insurance applicants for coverage and write business letters to those who do not qualify for coverage. Students deliver an oral presentation on the insurance company that they have developed and justify their decisions in the unit's Culminating Event.

Starting an Insurance Company

Part 2: The Policies

LESSON 3.1

HEALTH SCIENCE

Time

120 minutes

Materials

Equipment

Laptop computers for
“Writing a Policy”

Resources

- Insurance Vocabulary Cards
- Health Consumer Cards
- Health Event Cards
- Insurance Plan Choices handout
- Health Event Costs by Insurance Plan handout
- The insurance websites listed in Lesson 1.3.
- Choosing Healthplans All Together (CHAT) website (<http://www.changemakers.net/en-us/node/1459>)
- Health Insurance terms glossary (<http://www.healthinsurance.org/insterms.lasso>)

Prior Student Learning

Students should be able to read and understand healthcare plans (Lesson 1.3).

Students should have a general knowledge of healthcare terms.

Essential Question for This Unit

How can we balance personal freedoms and society’s need to provide accessible, affordable healthcare?

Objectives

After completing this lesson, students should be able to

- Interpret insurance policies with precision.
- Evaluate and compare several policies.
- Write a brief policy in clear, organized prose.

Lesson Activities

Lesson Springboard

Begin the lesson by providing students with the following scenario from someone who is “shopping” for health insurance:

“My agent says there’s an out-of-pocket maximum, for dependents too, but only if we stay within our PPO and don’t go out of the network. There’s a high deductible, though, and co-pays for brand names but not generics. Most of the other co-pays are for outpatient services; I’m not worried about that. But I am concerned about the exclusions and limitations, and the benefit period doesn’t kick in right away. Maybe we should shop around, and stay with our COBRA until we find a good HMO.”

Ask students whether all of this sounds kind of confusing. Explain to them that in this lesson, they will build upon what they learned in Lesson 1.3 and Lesson 1.4. They will learn to evaluate and compare insurance policies with precision and confidence. At the end, they will write a short insurance policy in clear English using accurate healthcare and health insurance terminology.

Lesson Development

Vocabulary

Hand out the Insurance Vocabulary Cards. Some of these cards contain healthcare terms such as *PPO*, *exclusions*, *fee for service*, *out-patient and in-patient services*, and *pre-existing conditions*. The other cards contain definitions of these terms. Ask students to move around the classroom, finding partners to match the terms with their definitions. Allow some time for partners to discuss the terms among themselves. This activity will also provide the foundation for the Insurance Simulation game that students will play later.

Starting an Insurance Company Part 2: The Policies

LESSON 3.1

Class Discussion

Ask partners to explain their terms to the class. Extend the discussion by posing questions like the following.

- Why might premiums be lower for an HMO than for a PPO or fee-for-service provider?
- What is the purpose of a waiting period? Of co-pays?
- Which terms are the most ambiguous, and therefore the most likely to cause disagreement between a client and provider?

Simulation

Here's some suggestions for how to perform the simulation:

Divide the students into groups of four to choose the most suitable policy for a health insurance consumer. Assign each group one consumer type: a married couple with kids, an aging widow, a young single man, and a middle-aged couple with no children at home. (Because there will be at least six groups, multiple groups will work with same consumer types.) Ask members of each group to discuss the facts about the type of consumer listed on the card, and then determine which of the four health plans they think is best to meet that consumer's needs.

Assign each student one of four health plans. Have a member of the group shuffle the deck of Health Event Cards. Ask each student to pick one card to discover what medical incident (if any) their consumer will confront in the coming month, and how much it will cost her based on the plan she chose. (The composition of Health Events in each deck is based on actuarial probabilities and is linked to the work students do later in Lessons 3.2 and 3.3. The cost to consumer is an estimate and cannot be determined exactly.)

The Health Event Card decks should be constructed as follows for each of the four consumer types:

Cards in Deck	Married With			Older Couple,
	Kids	Widow	Single Man	No Kids
Asthma	2	0	0	0
Car accident	1	0	2	0
Heart failure	0	2	0	1
Pregnancy	4	0	0	0
Alcohol	0	0	3	1
Diabetes	0	4	0	1
Physical	4	3	1	3
Pneumonia	2	3	0	0
Broken limb	2	2	2	1
No illness	15	16	22	23

Starting an Insurance Company Part 2: The Policies

LESSON 3.1

Play for 10 or 15 rounds and tally the health costs of each type of consumer for each plan. Did the group's original guess about the best plan turn out to have been the best choice? Why or why not?

Class Discussion

Students report back to the class and discuss issues like the following.

- Did all of the students in each group agree about policy choices for each type of consumer?
- Was this the best choice? Which parts of the policy were most significant for your consumer?
- Which policy terms did you most need to consider?
- If you were to write a policy, where is it most important to be clear?

Writing a Policy

Ask students to choose a policy from the samples provided and rewrite it in the form of a 500-word letter to their consumer. In clear and well-organized prose, ask that they describe the key benefits, limitations, and exclusions of the policy; availability of doctors and services; cost structure; and application requirements. The letter will begin by acknowledging the consumer's request for information and then will introduce the policy that the group has chosen to offer. It will conclude by describing the steps that the consumer must take next and will offer a way to acquire more information. The goal of this exercise is to synthesize technical information and turn it into readable, accurate prose.

Lesson Closure

Discuss how this lesson's simulation differed from the simulation that appeared in Lesson 1.1. Students should recognize that though paying for insurance may seem like wasted money if one remains healthy, having insurance is important to protect against the cost of unexpected illness or injury, which can be incredibly expensive.

Possible Prior Misconceptions

Students may believe that insurance plans are mostly equivalent or that having insurance means you have no out-of-pocket medical expenses.

Student Assessment Artifacts

Policy letter

Variations and Extensions

Add additional Health Event Cards, additional consumer types, and additional insurance plans to the simulation.

Discuss the extent to which the simulation accurately reflects health insurance and health events. Have students make changes to the simulation to make it more realistic.

Starting an Insurance Company Part 2: The Policies

LESSON 3.1

National and State Career Technical Education Standards

NATIONAL

NCHSTE National Healthcare Skill Standards

Foundation Standard 3: Systems

Healthcare workers will understand how their role fits into their department, their organization and the overall health-care environment. They will identify how key systems affect services they perform and quality of care.

- 3.2 Healthcare Delivery System
- 3.21 Construct a healthcare delivery system model
- 3.22 Predict where and how factors such as; cost, managed care, technology, an aging population, access to care, alternative therapies, and lifestyle/behavior changes may affect various healthcare delivery system models

CALIFORNIA

Health Sciences and Medical Technology Standards

10.0 Technical Knowledge and Skills

- 10.1 Understand the process for determining mission statements, goals, objectives, and strategic plans for a healthcare organization and understand the process for using appropriate policies, procedures, and processes as defined by the scope of practice of a specific healthcare organization.
- 10.2 Understand how the healthcare delivery systems models can be affected by cost, managed care, technology, an aging population, access to care, alternative therapies, and lifestyle and behavior changes.

Name _____ Date _____ Period _____

Health Insurance Vocabulary Cards

Co-pay	Money a person is required to pay for services, after the deductible has been paid.
Deductible	Amount a person must pay for health care expenses before insurance covers the costs. Insurance plans are often based on yearly deductible amounts.
Brand-name drug	Prescription drugs marketed with a specific brand name by the company that manufactures them. When patents run out, generic versions may be marketed at lower cost by other companies.
Cap	Short for capitation, a set dollar limit that you or your employer pay to a health maintenance organization (HMO), regardless of how much you use their services.
COBRA	Federal law that lets you continue to buy health insurance, if you're in a firm of 20 employees or more, for up to 18 months if you lose your job or your coverage is terminated.
Exclusions	Medical services not covered by an individual's insurance policy.

Name _____ Date _____ Period _____

<p style="text-align: center;">Generic drug</p>	<p>A “twin” to a “brand name drug” once the brand name company’s patent has run out and other drug companies are allowed to sell a duplicate of the original. Generic drugs are cheaper, and health plans reward clients for choosing them.</p>
<p style="text-align: center;">Health Maintenance Organization (HMO)</p>	<p>Represents “pre-paid” or “capped” insurance plans in which individuals or employers pay a monthly fee for services, instead of a separate charge for each visit or service. Services are provided by doctors under contract with the HMO.</p>
<p style="text-align: center;">In-network providers</p>	<p>Doctors or hospitals with which the health plan has negotiated a discount. Insured persons pay less when using them.</p>
<p style="text-align: center;">Lifetime Maximum Benefit</p>	<p>The maximum amount a health plan will pay in benefits during the insured person’s lifetime.</p>
<p style="text-align: center;">Limitations</p>	<p>A limit on amount of benefits paid out for a particular covered expense, as disclosed on the Certificate of Insurance.</p>
<p style="text-align: center;">Managed care</p>	<p>A medical delivery system that manages the quality and cost of medical services. Most managed care systems offer HMOs and PPOs that individuals are encouraged to use for their health care services.</p>
<p style="text-align: center;">Out-of-network providers</p>	<p>Doctors or hospitals who don’t participate in an insurance plan (usually an HMO or PPO). Depending on the plan, costs of their services may not be covered, or covered only in part, by the insurance company.</p>

Name _____ Date _____ Period _____

<p style="text-align: center;">Outpatient</p>	<p>A patient who does not stay overnight in a hospital. Insurance companies identify tests and procedures (including surgery) that will not be paid for unless they are performed on an outpatient basis.</p>
<p style="text-align: center;">Pre-existing conditions</p>	<p>A medical condition that is excluded from coverage by an insurance company, because it was thought to exist before the person bought the policy.</p>
<p style="text-align: center;">Preferred Provider Organization (PPO)</p>	<p>You or your employer receive discounted rates if you use doctors from a pre-selected group. If you use a physician outside the PPO plan, you must pay more.</p>
<p style="text-align: center;">Primary Care Provider (PCP)</p>	<p>A doctor who is responsible for monitoring one's overall health care needs. He or she refers the person to more specialized care when needed.</p>
<p style="text-align: center;">Short-term medical</p>	<p>Temporary coverage for a short time, usually 30 days to six months.</p>
<p style="text-align: center;">Waiting period</p>	<p>A period of time when you are not covered by insurance for a particular problem.</p>

Name _____ Date _____ Period _____

Health Consumer Cards

<p>Married couple in their 40s Two children ages 8 and 2 No major health problems Want one more child</p> <p>Covered for 50% of plan Can pay \$700 per month out of pocket</p>	<p>60-year-old widow Overweight High blood pressure Incipient glaucoma</p> <p>Covered for 60% of plan Can pay \$600 per month out of pocket</p>
<p>Self-employed man age 22 Truck driver in good health Seeks rehab for Benzedrine abuse</p> <p>Can pay \$300 per month</p>	<p>Married couple in their 50s No dependent children Wife disabled with arthritis Husband with high cholesterol</p> <p>Covered for 40% of plan Can pay \$500 per month out of pocket</p>

Name _____ Date _____ Period _____

Health Event Cards

<p>Child diagnosed with asthma Asthma/allergy specialist, six visits per year indefinitely</p>	<p>Annual physical check-up</p>
<p>Car accident, moderate injuries Requires four X-rays, 2 weeks in hospital, minor surgery, 3 months physical therapy, 3 months medication</p>	<p>Broken limb, sports injury Emergency room visit with two X-rays and overnight stay in hospital</p>
<p>Congestive heart failure 6 months medication at \$1,200 per month, EKG and other testing, 2 days in hospital</p>	<p>Pneumonia/Bronchitis Emergency Room visit and 3 weeks of medication</p>
<p>Complications in pregnancy Two doctor visits per month and six lab tests</p>	<p>No illness or injury</p>
<p>DUI indicates alcohol abuse Rehab program/Out-patient recovery services for 26 weeks</p>	<p>No illness or injury</p>
<p>Diabetes Monthly medication indefinitely Two visits to nutritionist</p>	<p>No illness or injury</p>

Name _____ Date _____ Period _____

Insurance Plan Choices

Service	Plan 1	Plan 2	Plan 3	Plan 4
Deductible	\$250 per person on plan per year	None	\$2,000 per person per year	\$2,900 per person per year
Hospital Inpatient Outpatient	85% after deductible same	\$100 co-pay \$10 co-pay	\$250 + 30% after deductible	40% after deductible same
Emergency Room	85% after deductible	\$50 co-pay	\$100 + 30% after deductible	\$100 + 40% after deductible
Physician Care: Office, Immunization, Gynecology	85% after deductible	\$10 co-pay	\$45 per visit	\$40 for 2 visits, then 100%
Surgical	85% after deductible	\$100 co-pay in hospital, \$10 co-pay for doctor	\$250 + 30%	40% of all costs
X-ray and Labs	85% after deductible	No charge	20% after deductible	100%
Routine Physical	85% after deductible	\$10 co-pay	\$50 co-pay	1 per year no cost
Maternity and Child Coverage	50% after deductible	\$100 per hospital admit	80% after deductible	Not covered
Rx Drugs	\$5 copy for generic, \$15 brand-name drugs	\$5 co-pay generics, \$15 brand-name drugs	\$10 co-pay generics, \$35 brand-name drugs	\$10 generic, brands not covered
Extended Care/Skilled Nursing	85% after deductible to 120 days max	No charge up to 100 days in benefit year	80% after deductible	85% after deductible to 60 days max
Alcohol, Drug Abuse Treatment	Hospital 85% after deductible; detox 30 days and rehab 60 days	Inpatient \$100 co-pay up to 30 days; Outpatient \$10 co-pay	Inpatient \$250 per admission plus 30%; Outpatient 30% up to 20 visits	40% of inpatient + outpatient costs

Costs of Plans (Including Employer Coverage)

Age	20–29	40–49	50–59	60–69
Plan 1	n.a.	\$800	\$1,100	\$1,400
Plan 2	\$250	\$600	\$800	\$1,000
Plan 3	\$200	\$500	\$700	\$800
Plan 4	\$75	\$325	\$500	n.a.

Name _____ Date _____ Period _____

Health Event Costs by Insurance Plan

Health Event	Plan 1	Plan 2	Plan 3	Plan 4
Car accident	\$4,150	\$1,000	\$8,800	\$16,400
Asthma	\$450	\$450	\$1,600	\$1,800
Diabetes	\$530	\$200	\$920	\$1,500
Pregnancy	\$900	\$120	\$2,070	\$140
Heart failure	\$1,950	\$800	\$5,650	\$5,960
Alcohol rehab	\$650	\$100	\$2,100	\$2,800
Physical	\$25	\$10	\$50	\$0/\$175
Broken limb	\$455	\$150	\$620	\$1,475
Pneumonia	\$225	\$50	\$350	\$375

Note: Out-of-pocket expenses for selected health event determined by online estimates for healthcare costs.

Dice With Death: Probability in Mortality Tables

LESSON 3.2

ALGEBRA I

Time

90 minutes

Materials

Equipment

- Graph paper
- Calculators

Resources

- Life expectancy and age, sex-adjusted, geographic, socio-economic, and race-indexed mortality figures (<http://www.gpoaccess.gov/index.html>)
- *Atlas of United States Mortality* from the National Center for Health Statistics (<http://www.cdc.gov/nchs/products/pubs/pubd/other/atlas/atlas.htm>)
- Mortality table from the Centers for Disease Control (<http://www.cdc.gov/nchs/data/dvs/life2002.pdf>)
- Smoking, occupation, and lung cancer table (<http://www.teacherlink.org/content/math/activities/ex-smoking/data.html>)

Prior Student Learning

Students should be able to graph linear functions, find the equation of a line, and estimate a “line of best fit.”

Essential Question for This Unit

How can we balance personal freedoms and society’s need to provide accessible, affordable healthcare?

Objectives

After completing this lesson, students should be able to

- Describe the connection between numerical, algebraic, and graphical representations of data.
- Analyze data using scatterplots, “lines of best fit,” and linear equations.

Lesson Activities

Lesson Springboard

Introduce this lesson with the following scenario:

A sophomore girl in the hiking club reaches for a grip on the cliff, but she slips and falls into the canyon below. An elderly man tosses in his bed, awakens, and gropes for his medication. He falls asleep, wrestles with the sheets, but by morning is dead. The same day, a few hours later, a housewife drives home from the grocery store through bright sunlight on the coast near Los Angeles, worrying about her daughter’s troubles in school. She reaches for a cigarette and accelerates to make the light, but misses it and is sideswiped by a city bus.

Fade to reality. These are some of the grisly deaths that opened several shows in the hit TV series *Six Feet Under* on HBO. We’re expected to believe these situations, but should we? How often do kids fall down cliffs? How often—do you think—are housewives hit by errant buses? Deaths on television dramas are one thousand times more common than in everyday life, according to one expert source. So, how probable are deaths from falls, from car accidents, or from old age? To find out, we will look at mortality tables. Given enough information about how people die, and when, we can say how likely it is that an individual will survive from one year to the next, and thus estimate the price for her insurance policy. If we know more about her—say, her race, medical history, or whether she smokes—we can refine our prediction, using mortality tables with several variables or even more.

Lesson Development

Class Discussion

Use the following questions to stimulate discussion in the class:

- What age groups do you predict are the most vulnerable to death?

Dice With Death: Probability in Mortality Tables

LESSON 3.2

- What factors might contribute to increased rates of death within those age groups?
- What age groups are least vulnerable, and why do you think so?

Group Activity—Analyzing Data (1)

Divide students into small groups (four to five students). Hand out the CDC mortality table to each group. Two groups will explain all of the headings in the table; two groups will search for interesting patterns in the data; and the remaining two groups will decide how to turn the table into a more revealing graph.

Reporting Back

Ask groups to share their work with the class. Encourage students to explain what they found in the data and why they wanted to create a certain type of graph. For example, through their work, they may be able to answer some of these questions:

What type of graph shows the data most clearly?

Why are year-to-year mortality rates useful? Can they be combined so that we can calculate mortality over a longer time span?

What are the most revealing cells in the mortality table?

Why is there a difference between life expectancy at birth and life expectancy beginning from a certain age—say, age 40 or 60? It seems the older you get, the longer you can expect to live. Can this fact be modeled by a graph? How would the graph look?

Group Activity—Analyzing Data (2)

Break students into small groups and hand out the Smoking and Lung Cancer table (see the Resources section above). Discuss the concept of an index for smoking and mortality. Why might an index be more useful than raw numbers?

Ask students to sort the data so that the smoking index is in ascending order, and then have them convert the table into a scatterplot. Ask them to describe the benefits of sorting data and creating the scatterplot.

You might also ask: How “strong” is the relationship between smoking and mortality? How would you *measure* the “strength” of this relationship? (One way is through correlation coefficients.)

Have students draw a “line of best fit” through the data points to approximate the trend they observe and to make predictions. Have students calculate the equation for this line and predict the mortality index for a smoking index of 120. (To find a line of best fit, you may use a least squares regression line. See Variations and Extensions.)

Dice With Death: Probability in Mortality Tables

LESSON 3.2

Explain to students that their equation will predict the mortality index of each occupational group. Ask them: How does this compare to the actual mortality values in the table? (The difference between a predicted and actual value is called a *residual*. For more information, see Variations and Extensions.)

From your analysis, is smoking related to lung cancer? Can you say that smoking *causes* lung cancer?

Lesson Closure

Ask students to consider how mortality tables might be used to inform insurance companies seeking to set insurance rates.

Possible Prior Misconceptions

Some students may have difficulty distinguishing correlation and causality. This can sometimes be addressed by providing examples of correlations between events that clearly have no causal relationship.

Some students may have an overinflated sense of the predictive power of correlations and probability.

Student Assessment Artifacts

Scatterplots of data

Variations and Extensions

Students can research correlation coefficients and the concept of variance on the Internet, and then report what they found in class. Advanced students will be interested in regression lines. All students may be assigned **homework** on the nature and use of residuals and on how to interpret statistical “outliers.”

National and State Academic Standards

NATIONAL NCTM Standards for School Mathematics

Data Analysis and Probability

- Formulate questions that can be addressed with data and collect, organize, and display relevant data to answer them
- Select and use appropriate statistical methods to analyze data

CALIFORNIA Mathematics Content Standards

Probability and Statistics

- 8.0 Students organize and describe distributions of data by using a number of different methods, including frequency tables, histograms, standard line and bar graphs, stem-and-leaf displays, scatterplots, and box-and-whisker plots.

Medical Coverage Choices

LESSON 3.3

ALGEBRA I

Time

50 minutes

Materials

Equipment

- Graph paper
- Calculators
- Rulers

Resources

Sample medical insurance applications with descriptions of different plans. Here are some possible links:

- <http://www.hcahealthcare.com>
- <http://kaiserquotes.com/>
- <http://www.aetna.com/members/individuals/health/plans.html?state=California>
- http://www.aetna.com/members/individuals/health/data/rates_California.pdf

Prior Student Learning

Students should already be familiar with graphing linear equations.

It would be helpful, but not essential, if students were familiar with different types of healthcare plans and could define the terms *co-pay*, *premium*, *deductible*, and *generic* and *brand-name medications*.

Essential Question for This Unit

How can we balance personal freedoms and society's need to provide accessible, affordable healthcare?

Objectives

After completing this lesson, students should be able to

- Make and justify real-world healthcare decisions by modeling situations using linear graphing.
- Solve linear equations and analyze systems of linear equations by graphing.

Lesson Activities

Lesson Springboard

Ask students if they know how much their parents pay each time they visit a doctor if they are sick or are going for a check-up. There will probably be a range of answers. Ask them whether this is the only cost of seeing a doctor, or if there are other amounts that their parents have to pay? If students are not already familiar from their own experience or from an earlier lesson in this unit, introduce them to the general concepts behind premiums, co-pays, and deductibles.

Tell students that if they are fortunate enough to have a job where their employer pays for full medical benefits, the only costs they would have to worry about typically are the deductibles and co-pays for doctors' visits and prescriptions. However, many companies share the premium costs with the employee, and some companies do not offer any medical benefits. Further, some employees cover family members, some share the cost of insuring family members, and others will not cover family members at all. These different scenarios lead to a complex array of choices and difficult decisions to consider both before accepting a job and afterwards when you apply for insurance.

Most companies allow employees to change their health insurance plan only once a year at a specific time. Tell the class that they need to come up with a logical decision-making model to help them choose appropriate healthcare plans, so that they don't make a costly mistake.

Lesson Development

Small Group Work

Tell the class that they have been hired into jobs with employers who do not offer healthcare benefits. They must buy it themselves and incur the entire cost out-of-pocket. Hand out samples of individual medical insurance plans, with their premiums, deductibles, and co-pays.

Medical Coverage Choices

LESSON 3.3

Tell the class that there are several considerations when choosing appropriate health plans. For example, it is simpler if the co-pay for doctors' visits and medications are the same, or if students assume that they do not take regular medications—to eliminate this variable altogether. Further, premiums are often listed as a cost per month. Depending on the questions that the final graphs are intended to answer, it may be convenient to convert these figures into cost per year before handing out the information, or have the students do this conversion themselves.

Ask groups to work together and write equations to describe the total cost of medical care for each plan, given the number of doctors' visits (and/or medication co-pays). The number of visits is the independent variable in this case. Then ask each group to graph the equation of a different insurance plan and briefly present it to the class. Inform them that the total premium should be the y -intercept of the line (it is a fixed cost you pay regardless of whether you see the doctor at all); the deductible may put a "bump" in the graph; and the co-pay determines the slope of the line.

If there is time, ask students where the x -intercept is in on the graph, and what, if anything, it represents in this situation.

Work in Pairs

Suggest to the class that while the graphs they have created are useful, they don't immediately illustrate which plan is better for individuals depending on how many times they go to the doctor. Explain that displaying two plans on the same graph would make comparing them easier.

Separate the class into pairs, with each partner getting a graph of a different medical plan. Assign each pair to graph their plans on the same set of axes.

Discussion

Through discussion with individual pairs or the entire class, have students explain the meaning of the intersection of the two lines they graphed. Check for their understanding by asking the meaning of the y -intercept and slope of each line, what the fixed and variable costs are in this situation, and what it would mean if the two lines never crossed.

Lesson Closure

Finally, have students explain in writing which of the two healthcare plans they analyzed would be the most inexpensive for them. Then ask them to describe a person who would be better off choosing the other plan of the two. Discuss how likely it would be that two plans would be entirely equal in cost for a particular person, and/or present situations when it didn't matter which of the two plans you actually had, even though in theory one was better than the other.

Possible Prior Misconceptions

Students may think that insurance co-pays are the only cost of a doctor's visit.

Medical Coverage Choices

LESSON 3.3

Students sometimes assume that linear functions always go through the origin.

Students may not think about whether units and variables have to match in order for systems of equations to make sense.

Student Assessment Artifacts

Graph of individual plan

Graph of system of equations (two plans)

Written assessment of which healthcare plan is best for the student

Variations and Extensions

Students can be introduced to solving systems of equations algebraically to calculate the exact intersection point of two lines. They can check their answers in this lesson with a graphing calculator.

Problems become more complicated and realistic when medications are added to the equation. Students can analyze systems with three or more variables.

Students can simulate the decision-making process of a married couple with jobs that offer different health coverage options for family members and different levels of cash back for opting out of their company's coverage.

Students can create their own math problems that involve deciding between different options. Some examples are cell phone plans, transportation options, car loans, and other purchasing decisions.

National and State Academic Standards

NATIONAL NCTM Standards for School Mathematics

Algebra

- understand patterns, relations, and functions;
- represent and analyze mathematical situations and structures using algebraic symbols;
- use mathematical models to represent and understand quantitative relationships;
- analyze change in various contexts.

CALIFORNIA Mathematics Content Standards

Algebra I

- 5.0 Students solve multistep problems, including word problems, involving linear equations and linear inequalities in one variable and provide justification for each step.
- 6.0 Students graph a linear equation and compute the x - and y -intercepts (e.g., graph $2x + 6y = 4$). They are also able to sketch the region defined by linear inequality (e.g., they sketch the region defined by $2x + 6y < 4$).
- 7.0 Students verify that a point lies on a line, given an equation of the line. Students are able to derive linear equations by using the point-slope formula.
- 9.0 Students solve a system of two linear equations in two variables algebraically and are able to interpret the answer graphically. Students are able to solve a system of two linear inequalities in two variables and to sketch the solution sets.

Designing a Wellness Program

LESSON 3.4

PHYSICAL EDUCATION

Time

90 minutes

Materials

Websites that describe company and school Wellness Programs:

- Wellness Councils of America (<http://www.welcoa.org/wellworkplace/>)
- Healthy Ohio Brochure on Wellness (<http://www.healthyohioans.org/aboutus/aboutus.aspx>)
- Take Action! California 5 A Day-Be Active! Worksite Program (<http://www.takeactionca.com/>)
- The American Heart Association website (<http://www.HealthierGeneration.org>)
- Prevention/Wellness Program handout

Prior Student Learning

Students should have a general knowledge of the components of wellness, such as nutrition, fitness, and prenatal care. They should have conducted preliminary Internet research on the elements of a good workplace wellness program and identified several programs.

Students should understand such wellness “indicators” as resting pulse, BMI, and blood pressure levels.

Essential Question for This Unit

How can we balance personal freedoms and society’s need to provide accessible, affordable healthcare?

Objectives

After completing this lesson, students should be able to

- Explain the components of wellness and how they interrelate.
- Evaluate fitness needs of various groups, using several diagnostic tools, and measure their progress.
- Relate the goals of wellness programs to the goals and policies of insurance companies.

Lesson Activities

Lesson Springboard

Explain that “wellness” has several components; that a Wellness Program must serve a variety of individuals’ needs; and that finding both the right “mix” of components and a method to evaluate them are a challenge to teachers of Physical Education. Students can start examining Wellness Programs before the lesson by viewing a brief presentation on the American Heart Association’s website: http://www.HealthierGeneration.org/uploadedFiles/For_Schools/staff_wellness_tk%203.pdf.

Lesson Development

Small Groups

Pass out examples of Wellness Programs to the class. Working in small groups, have students review and compare the programs they identified in their research before the lesson and the ones you have distributed. Are there certain common elements? Which programs appear to be the most comprehensive? Which programs appear to be the most inviting? Why?

Activity

Note the importance of benchmarks as a starting point for evaluating a Wellness Program. Have students take one another’s resting pulse—as an example of a wellness benchmark—and calculate their own Body Mass Index (BMI). Discuss with the class why these are good benchmarks and connect them to what students have learned in Health Science about cardiovascular disease and the medical consequences of obesity.

Designing a Wellness Program

LESSON 3.4

Class Discussion

After students have researched and evaluated several actual Wellness Programs on their own and discussed them in small groups, ask the entire class to discuss the components of wellness drawing upon this research. Communicate to students that most wellness programs have the following components:

- A needs assessment
- Nutrition
- Fitness
- Alcohol, tobacco, and drugs cessation
- Early detection and prevention (immunizations, mammograms, flu shots, cholesterol and blood pressure screenings, etc.)
- Prenatal care
- Stress management

For each category, what are the success stories that students were able to find in their research? How are they measuring success? Why do companies use success stories when advertising their wellness programs? Did the students' research uncover any information on ways to estimate company savings on healthcare costs due to instituting a wellness program?

Application

Divide students into four “wellness teams” and design a program for a particular category of employees (or “sick situation”). The four sick situations include a Silicon Valley high-technology company with mostly young employees, where stress reduction is paramount; a trucking firm where workplace injuries are frequent; a nonprofit with mostly female employees who need prenatal care, mammograms, and efforts aimed at their families; and a school district where many students are obese and physically unfit.

Each wellness team includes an assessor (to identify needs and evaluate outcomes), an accountant (to estimate costs), one or more physical educators (to design programs), a secretary, and a spokesperson (to report back to the class). Distribute the following questions and tell students that you will use the questions to guide the class discussion when the wellness teams report back to the class:

- Is there overlap among components of the wellness program with respect to their objectives—e.g., does fitness reduce stress? Does good nutrition help young mothers as well as members of their families?
- What is the balance between on-site resources and outside ones in the program they have designed? Why are both included?
- How does your Wellness Program draw upon physical education resources in the community? Why is this important?

Designing a Wellness Program

LESSON 3.4

- What data were useful for assessing your clients' needs (screenings, claims analysis, demographics of your population)?
- What methods were useful for evaluating your Wellness Program?

In the final class segment, the teams report back to the entire class, describing their sick situation and key points of their Wellness Program and answering the questions distributed earlier.

Lesson Closure

Assign students the task of designing a general Wellness Program that would be sponsored by their fictitious insurance company.

Student Assessment Artifacts

Completed Prevention/Wellness Programs

Variations and Extensions

Invite a guest speaker to discuss corporate Wellness Programs.

National and State Academic Standards

NATIONAL

NASPE National Standards for Physical Education

Physical activity is critical to the development and maintenance of good health. The goal of physical education is to develop physically educated individuals who have the knowledge, skills, and confidence to enjoy a lifetime of healthful physical activity. The physically educated person:

3. Participates regularly in physical activity
4. Achieves and maintains a health-enhancing level of physical fitness

CALIFORNIA

California has no state standards for Physical Education at this time.

Name _____ Date _____ Period _____

Prevention/Wellness Program

You are asked to create your own Wellness Component Feature for your insurance company.

Many insurance companies today create a prevention program for individuals who subscribe to the program. The idea is to help lower overall costs of healthcare. It is an incentive program. **If members participate in this program, their premiums (how much insurance costs) are lowered each month or they receive some sort of discount.** The idea is that it is more cost effective for insurance companies to give discounts for prevention services than to pay for expensive chronic diseases or accidents down the road.

DIRECTIONS:

Give your insurance company a Prevention/Wellness Program. Decide how many points will be awarded for participation in the program each year and how much of a discount will be awarded for the amount of points. Be specific about wellness activities and how many points each one is worth.

EXAMPLE:

50 points a year–5% discount

150 points a year–10% discount

250 points a year–15% discount

Point System

Points for

- participating in a run/walk race
- attending smoking cessation or drug rehab classes
- attending wellness classes through hospitals or doctors' offices
- evidence of regular doctor check-ups

Straight Discounts for

- evidence of attending a gym 3 days a week
- joining any weight management program
- proof of regular vaccinations each year

FINAL PRODUCT

A document that details the prevention plan/wellness program for your insurance company will be handed in on or before the due date. You will add this to your final project with your group.

Starting an Insurance Company

Part 3: Choosing Clients

LESSON 3.5

ENGLISH LANGUAGE ARTS

Time
120 minutes

Materials

- Medical Insurance Questionnaire
- Tough Choices worksheet

Prior Student Learning

Students should have finished all other unit lessons before starting this one.

Essential Question for This Unit

How can we balance personal freedoms and society's need to provide accessible, affordable healthcare?

Objectives

After completing this lesson, students should be able to

- Evaluate potential insurance clients and make decisions about which individuals present the greatest and least risk.
- Compose a business letter.
- Deliver an oral presentation to a professional audience.

Lesson Activities

Teacher Preparation

Before starting this lesson, obtain the completed Medical Insurance Questionnaires that the Biology teacher distributed to colleagues asking them to create profiles of potential insurance “clients” for Lesson 2.3. If a Biology teacher is not part of your instructional team, distribute these questionnaires yourself, following the instructions in the Biology lesson.

Lesson Springboard

Pass out the Tough Choices worksheet. Ask students to rank their choices for insuring individuals as if they were insurance agents. Remind them that individuals with low risks for health problems are usually more desirable as clients. After students have completed their rankings, have them share their work with others in the class. Discuss the differences in rankings across the class.

Lesson Development

Small Group Work

Have students assemble in their Insurance Company groups. Give each group a set of the Medical Insurance Questionnaires that were completed by school staff to represent potential clients (see Teacher Preparation above) and ask them to evaluate the “applications.” Based on the information they have learned in various lessons throughout the unit, students should evaluate which clients to accept and which clients to reject for insurance.

Starting an Insurance Company Part 3: Choosing Clients

LESSON 3.5

Writing Assignment

Ask students “Why do people write letters?” List all reasons for writing letters on the board (possible kinds of letters include thank you, persuasive, complaint, informational, and so on). Explain to students the difference between “formal” and “informal” letters. Introduce or review the format of a business letter with the class.

Tell students that they will be writing a formal business letter to their “high-risk” applicant. Encourage students to reflect on the information from the insurance company brochures they developed earlier to provide reasons for denying medical insurance to these high-risk people.

Presentation and Display

Working in their Insurance Company groups, have students create a display of the materials they have created for their Insurance Company, including

- Company’s name, logo, slogan, and vision statement
- Workplace brochure
- High-risk behavior fact sheet
- Policy statement
- Wellness Plan
- Client profile
- Family pedigree chart
- Rejection letter

Lesson Closure

Have students set up their displays around the classroom. Invite school staff to visit the class, talk to students about their displays, and provide feedback. Use this preview experience as preparation for the unit’s Culminating Event in which healthcare and postsecondary partners will visit the school and evaluate the students’ work.

Student Assessment Artifacts

Rejection letter

Insurance company display

Variations and Extensions

To make the assignment more complex, tell students that according to new state regulations, no applicant can be turned down for health insurance. However, premiums can vary within a certain range depending on the applicant’s risk status. Ask students to use the information they developed in Lesson 3.3 to write a letter accepting a high-risk applicant and explaining in detail the reason for the company’s high premium cost.

Starting an Insurance Company Part 3: Choosing Clients

LESSON 3.5

National and State Academic Standards

NATIONAL

NCTE Standards for the English Language Arts

5. Students employ a wide range of strategies as they write and use different writing process elements appropriately to communicate with different audiences for a variety of purposes.
6. Students apply knowledge of language structure, language conventions (e.g., spelling and punctuation), media techniques, figurative language, and genre to create, critique, and discuss print and non-print texts.

CALIFORNIA

English Language Arts Content Standards

Writing

- 2.5 Write business letters:
 - a. Provide clear and purposeful information and address the intended audience appropriately.
 - b. Use appropriate vocabulary, tone, and style to take into account the nature of the relationship with, and the knowledge and interests of, the recipients.
 - c. Highlight central ideas or images.
 - d. Follow a conventional style with page formats, fonts, and spacing that contribute to the documents' readability and impact.

Dear Colleague,

Please fill out five copies of this *Medical Insurance Questionnaire* to create profiles for five “applicants” who are seeking health insurance. Fill them out as if a real person were filling out the questionnaire. Try to create a spectrum of applicants representing high to low risk. For example, create profiles for two or three high-risk and two or three low-risk applicants.

Please be creative. The details that you add to each profile in the sections on “family history” and “personal history” will add to the authenticity of this material. These open-ended items on the questionnaire are meant for you to be able to expand on the applicants’ backgrounds. For example, if your “applicant” contracted an STD or is sexually promiscuous, please include this information in the “personal history” section.

If you have any questions, let me know!

Thanks!

Medical Insurance Questionnaire



Name: _____

Age: _____ Sex: _____ Occupation: _____

Height: _____ Weight: _____ Blood Pressure: _____

Current Medications:

Hobbies and Interests:

Do you smoke? Yes/No

If yes, how many packs of cigarettes do you smoke per week? _____

Do you drink alcohol? Yes/No

If yes, how many alcoholic beverages do you consume per week? _____

Do you use illegal drugs? Yes/No

If yes, list the name(s) of the drug(s) and how often you use each:

Name: _____ How often? _____

Name: _____ How often? _____

Name: _____ How often? _____

Do you exercise? Yes/No

If yes, describe the type(s) of exercise:

How many times per week? _____

Family History:

Personal History (including hospitalizations):

Name _____ Date _____ Period _____

Tough Choices



Who would you insure? Rank each individual (1 through 10) with #1 being your highest choice to insure and #10 being your lowest choice:

- _____ Teenage pregnant girl
- _____ 75-year-old grandmother with Alzheimer's disease
- _____ 5-year-old boy with liver cancer
- _____ 35-year-old business woman with recurring migraine headaches
- _____ 19-year-old college student with past history of three car accidents
- _____ 22-year-old woman with HIV infection
- _____ 50-year-old professional man with history of alcoholism
- _____ 28-year-old man who has recovered from 3 years of methamphetamine addiction
- _____ 45-year-old mother of three with high blood pressure
- _____ 58-year-old Vietnam veteran with depression and Post Traumatic Stress Disorder